



US006932713B1

(12) **United States Patent**
Kim

(10) **Patent No.:** **US 6,932,713 B1**
(45) **Date of Patent:** **Aug. 23, 2005**

(54) **GOLF TEACHING APPARATUS AND METHOD**

5,551,696 A 9/1996 Izett et al.
5,997,408 A * 12/1999 Bankhead 473/227
6,004,221 A 12/1999 Thornhill
6,358,156 B1 3/2002 Moran
6,471,598 B2 10/2002 Takase

(76) Inventor: **Hyoung J. Kim**, 12819 SE. 38th St., #144, Bellevue, WA (US) 98006

(*) Notice: Subject to any disclaimer, the term of this patent is extended or adjusted under 35 U.S.C. 154(b) by 0 days.

* cited by examiner

Primary Examiner—Stephen Blau
Assistant Examiner—Nini F. Legesse
(74) *Attorney, Agent, or Firm*—Hughes Law Firm, PLLC; Robert B. Hughes

(21) Appl. No.: **10/943,763**

(22) Filed: **Sep. 17, 2004**

(57) **ABSTRACT**

Related U.S. Application Data

(60) Provisional application No. 60/504,465, filed on Sep. 17, 2003.

(51) **Int. Cl.**⁷ **A63B 69/36**

(52) **U.S. Cl.** **473/266; 473/227**

(58) **Field of Search** 473/207, 215, 473/219, 226, 227, 266, 276, 277

An apparatus and method for assisting a golfer to improve his/her putting stroke. The apparatus comprises two elongate positioning members having two upper end portions which the golfer places between his/her upper arm portions and upper side torso portions. The shaft of the putter is connected to the two lower end portions of the positioning members. The golfer grasps the hand grip of the putter while his/her upper arms press against the upper end portions of the positioning members. Thus the golfer's upper torso portion, the two positioning members, and the putter, are substantially stationary relative to one another. Then the golfer properly executes the putting stroke by moving the upper torso to cause the golfer's arms, the positioning members and the putter to move as a unit with the golfer's upper torso portion.

(56) **References Cited**

U.S. PATENT DOCUMENTS

3,595,583 A 7/1971 Oppenheimer
4,582,325 A 4/1986 Yuhara
5,156,401 A 10/1992 Hodgkiss
5,342,055 A 8/1994 Diley
5,465,971 A 11/1995 Tischler
5,520,392 A * 5/1996 Foresi et al. 473/227

22 Claims, 9 Drawing Sheets

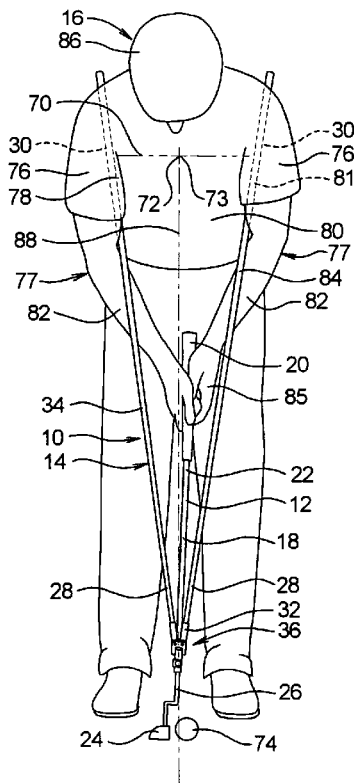

FIG. 4

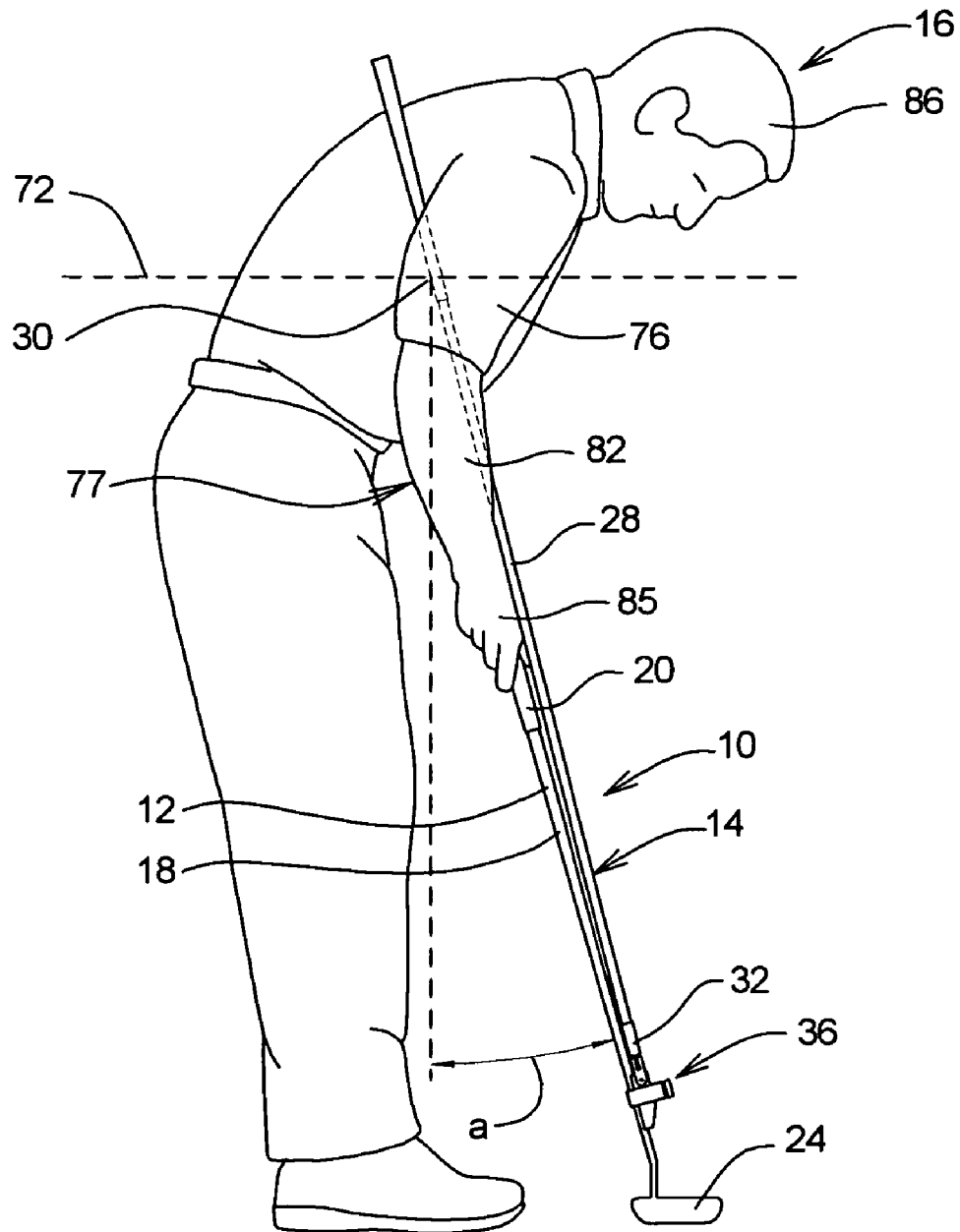

FIG. 4A

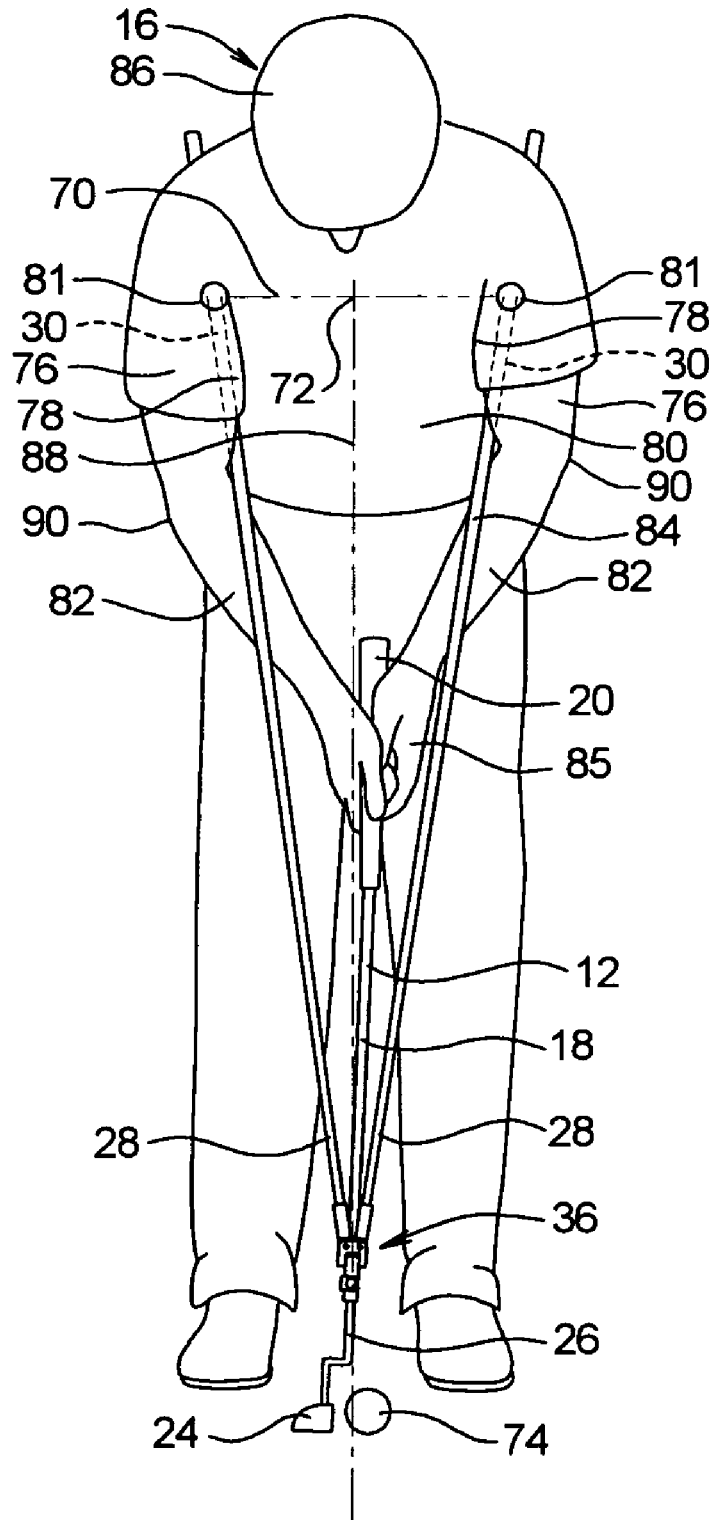

FIG. 5

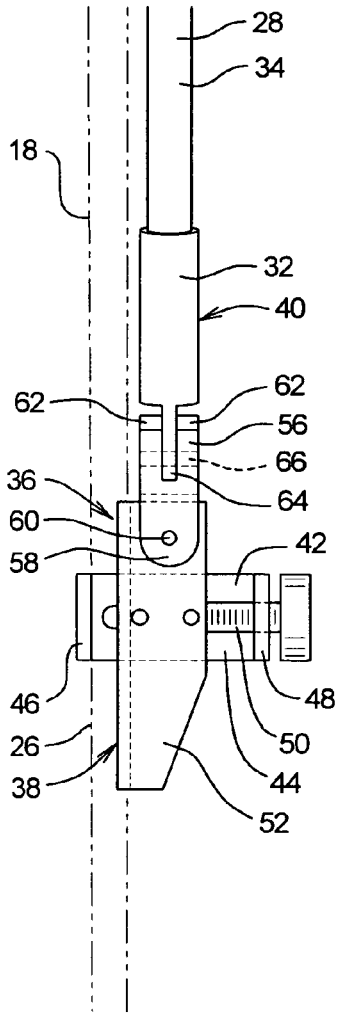

FIG. 6

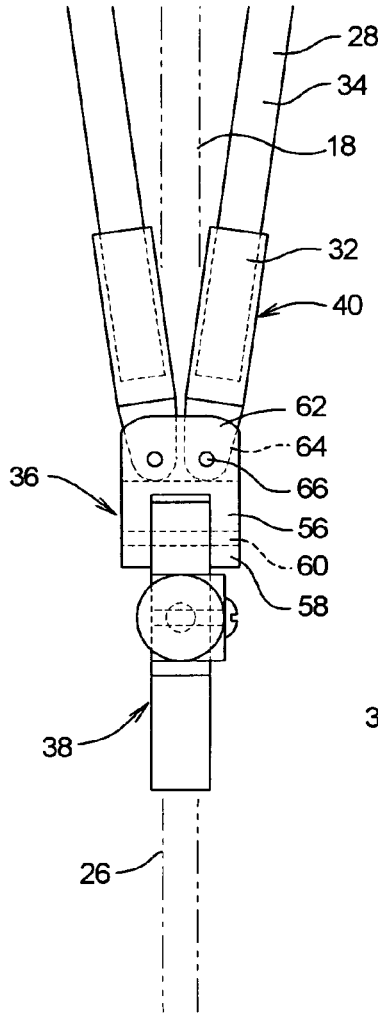

FIG. 7

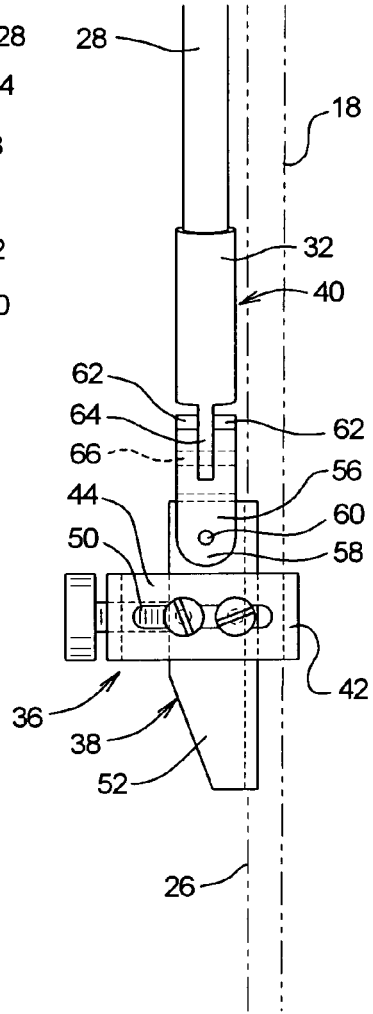

FIG. 8

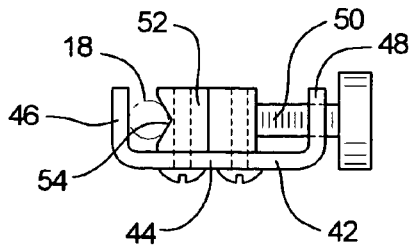

FIG. 9

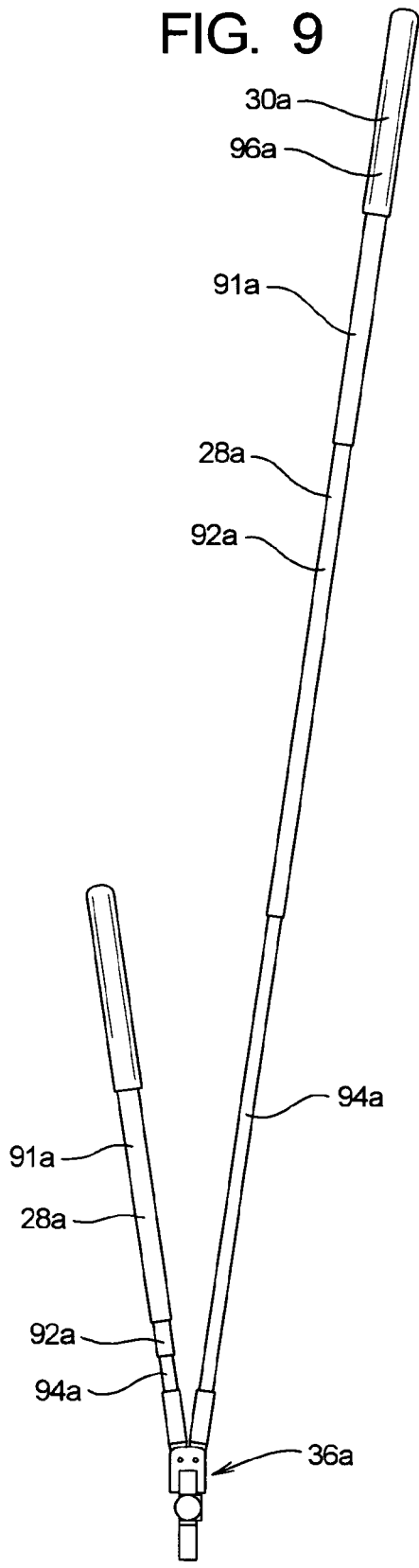

FIG. 10

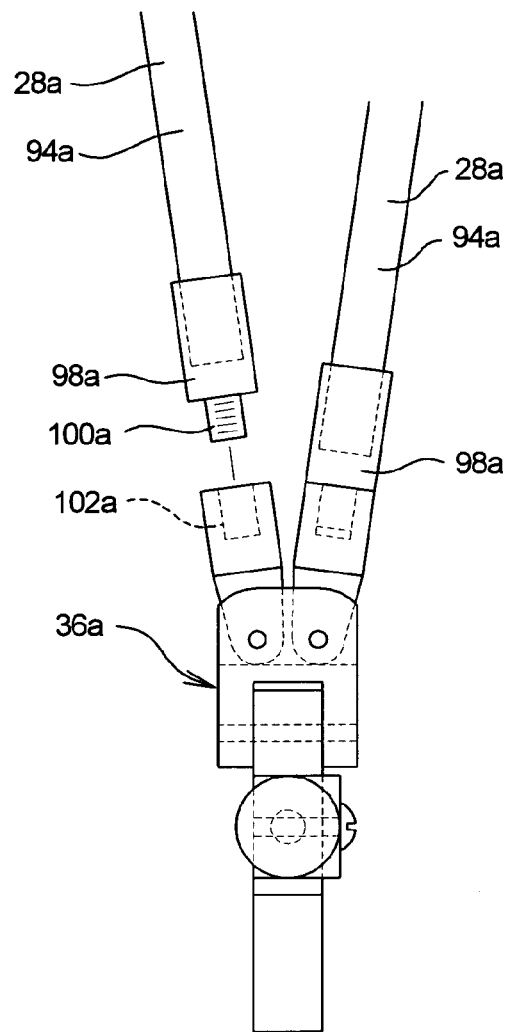

FIG. 11

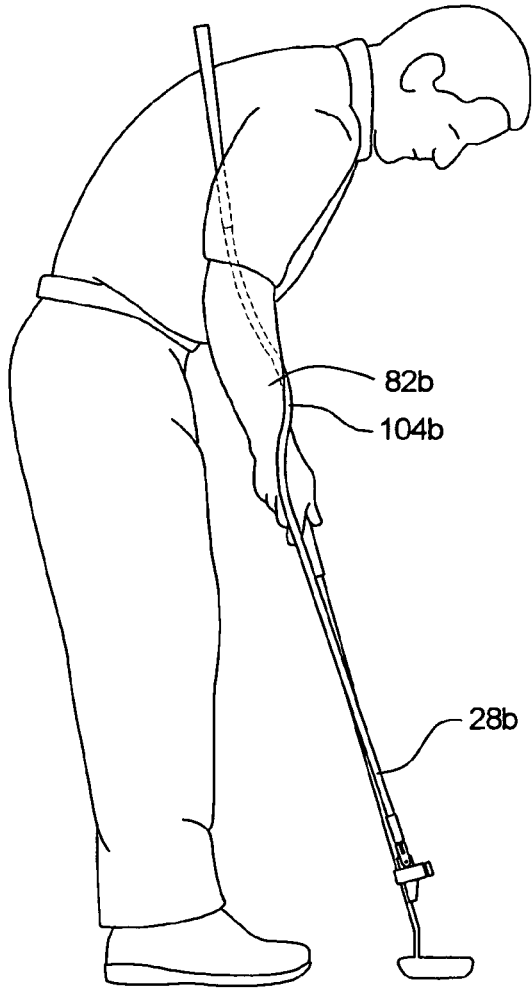

FIG. 12

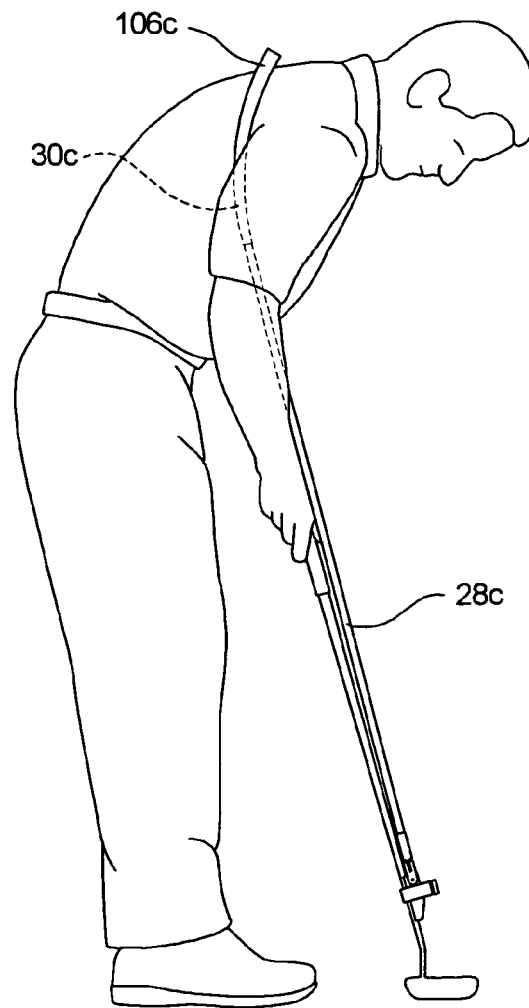

FIG. 13

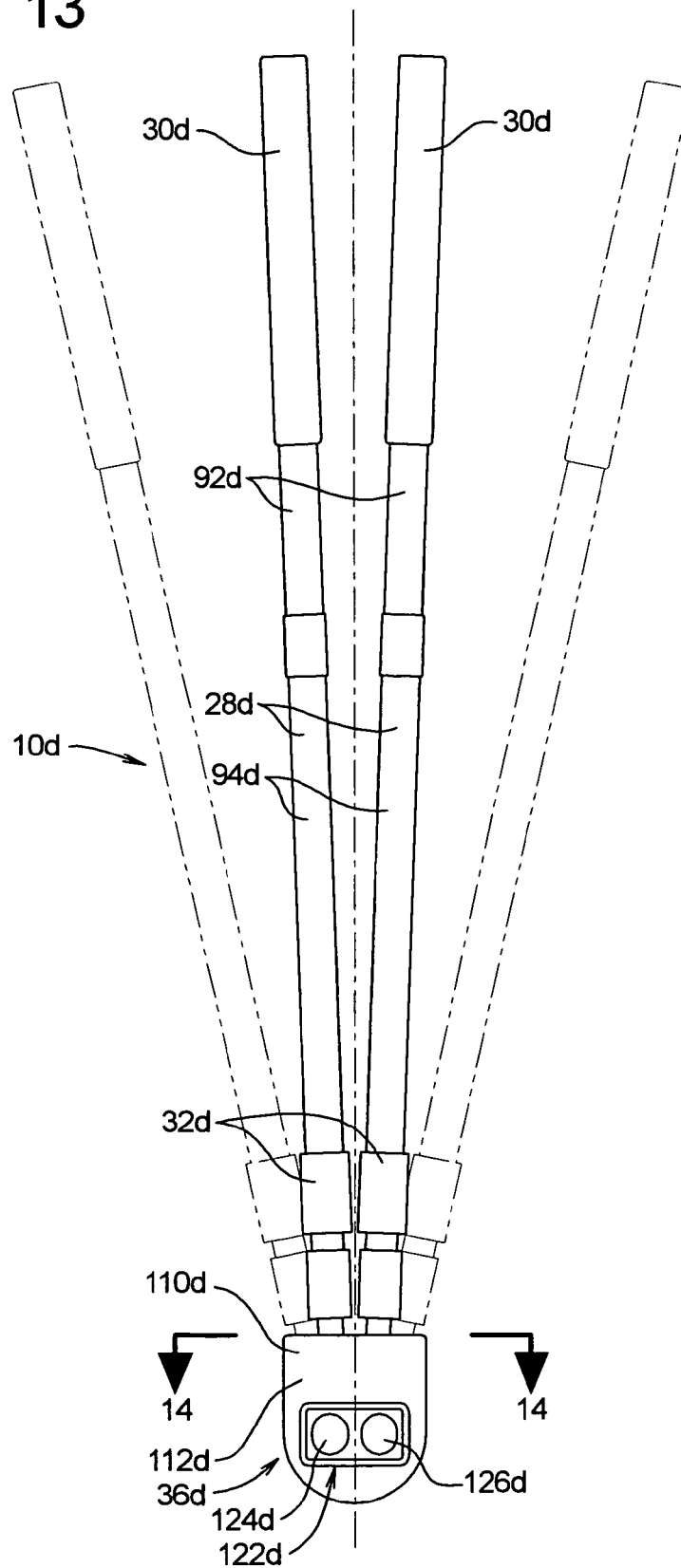

FIG. 14

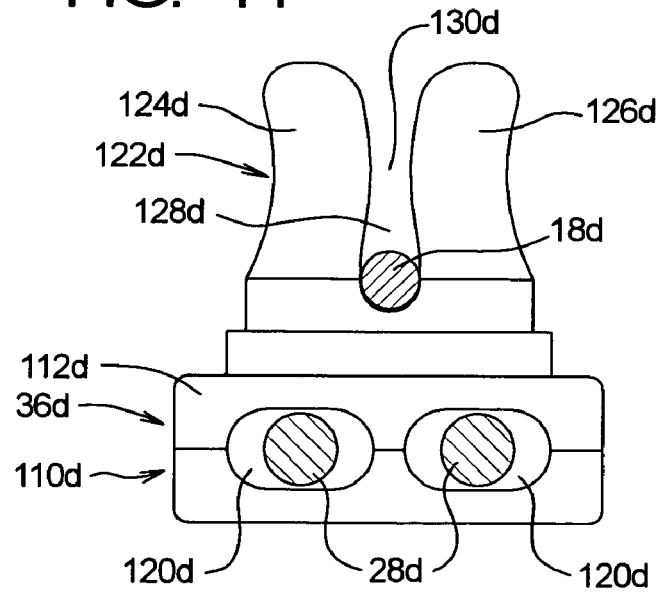
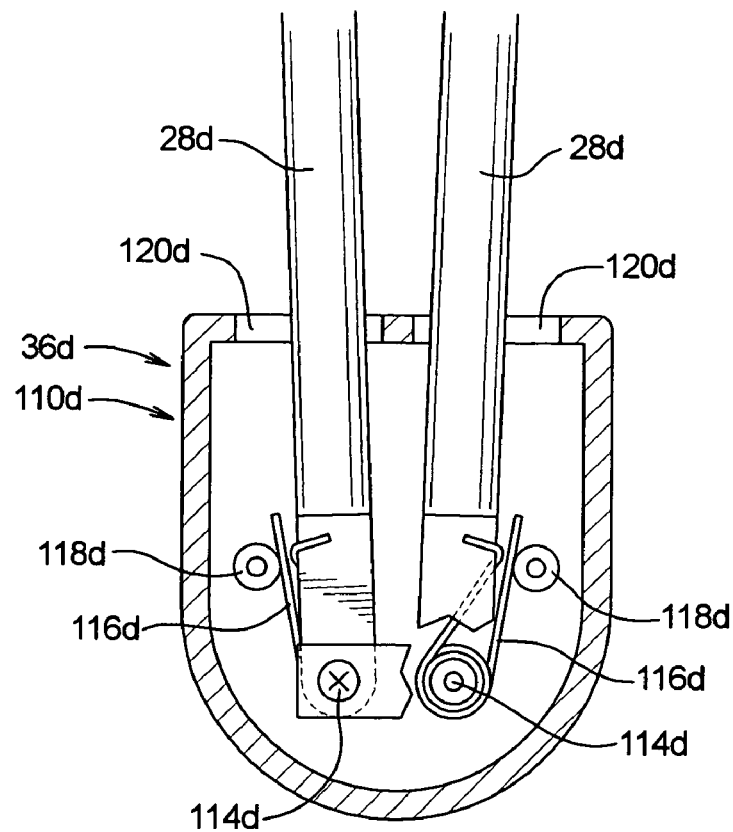

FIG. 15



GOLF TEACHING APPARATUS AND METHOD

RELATED APPLICATIONS

This application claims priority benefit of Provisional Application U.S. Ser. No. 60/504,465, filed Sep. 17, 2003.

BACKGROUND OF THE INVENTION

a) Field of the Invention

The present invention relates to an apparatus and method for improving a person's golf game, and more particularly to a teaching apparatus and method to improve and develop a putting stroke.

b) Background Art

Over a number of decades, various devices and methods have been designed for improving a person's golf game. A number of these have been mechanical devices to cause the person's golf swing to be executed along a desired path and/or in a certain manner, and also for properly positioning the golfer in the initial stance and the execution of the stroke.

A search of the U.S. patent literature has disclosed a number of these, and these are as follows:

U.S. Pat. No. 5,156,401 (Hodgkis) shows a device which is an attachment to a putter. There is provided a cross-member **12** having end portions **23**, and this cross-member **12** is rigidly attached to the putter. As a person grasps the putter handle, the two end portions **23** of the cross-member **12** fit beneath the person's arms on opposite sides of the person's chest. The purpose of this is to make contact with the person's body in such a manner so as to restrain the movement of the golf club along a predetermined path.

U.S. Pat. No. 6,471,598 B2 (Takase) shows a device that attaches to the club and the user's left arm to train the golfer to move the club in a straight path.

U.S. Pat. No. 6,358,156 B1 (Moran) provides a device that binds the player's arms in the proper position for holding the club and exacting a proper swing. The guiding device is joined to the club guiding it as well as the golfer's motions.

U.S. Pat. No. 6,004,221 (Thornhill) shows a framework that attaches to the putter and contacting either side of the user's body.

U.S. Pat. No. 5,551,696 (Izett et al.) shows a two-handled putter that is held in each hand. Some of the embodiments include handles of different lengths.

U.S. Pat. No. 5,465,971 (Tischler) shows a training aid that engages the user's right armpit, and tends to direct and align the club.

U.S. Pat. No. 5,342,055 (Diley) provides a putting training aid that engages the club and loops around the neck to help align the club.

U.S. Pat. No. 4,582,325 (Yuhara) shows a device that generates a signal to a computer or the like that can be used to analyse the swing motion. The device appears that it may also aid in providing guidance for the club's path.

U.S. Pat. No. 3,595,583 (Oppenheimer) provides a framework and a means to guide a golfer's swing.

BRIEF DESCRIPTION OF THE DRAWINGS

FIGS. **1**, **2**, and **3** are front views showing a golfer utilizing the apparatus of the present invention, with FIG. **1** showing a golfer in the putting stance at the start of the putting stroke, FIG. **2** showing the completion of the back

swing, and FIG. **3** showing the golfer and the apparatus positioned at the completion of the putting stroke;

FIG. **4** is a side elevational view of the golfer and the apparatus as shown in FIG. **1**;

FIG. **4A** is substantially the same as FIG. **1**, but for purposes of illustration some of the numerical designations have been omitted, and the designations included are to indicate certain key components and/or locations in the functioning of the present invention;

FIG. **4B** is a schematic drawing showing in a schematic form the components and relationships that are shown in FIG. **4A** and discussed in the text relative to FIGS. **4A** and **4B**;

FIG. **5** is a side view of the connecting section by which components of the apparatus are joined one to another and making a connection with the lower end of the shaft;

FIG. **6** is an elevational view taken from the left side of FIG. **5**;

FIG. **7** is a side elevational view taken from the opposite side relative to FIG. **6**;

FIG. **8** is a bottom view of the connecting section as shown in FIG. **5**;

FIG. **9** is a view of a second embodiment of the apparatus, where positioning members are made as telescoping members;

FIG. **10** is a view of the second embodiment where the positioning members are shown as being removably attached to the connecting section;

FIG. **11** is a side elevational view similar to FIG. **4**, showing a third embodiment of the present invention; and

FIG. **12** is a view similar to FIG. **11**, showing a fourth embodiment of the present invention.

FIG. **13** is a view of a fifth embodiment of the present invention taken from a view in front of the apparatus;

FIG. **14** is a sectional view along line **14—14** of FIG. **12**; and

FIG. **15** is a view taken from the same location as FIG. **13**, but having the front cover portion of the connecting section removed.

EMBODIMENTS OF THE PRESENT INVENTION

It is believed that a clearer understanding of the apparatus **10** of the present invention and the method associated with the same will be obtained by first describing generally the overall configuration of a first embodiment of the present invention and the manner in which it is used. This will be followed by a more detailed description of various functional relationships of this first embodiment, and then a description of the further embodiments.

The present invention is a teaching apparatus designed to assist a golfer in improving his/her putting stroke, and the apparatus **10** can be described as functioning as a positioning and stroke control apparatus. Reference is first made to FIGS. **1—3**, which show the apparatus **10** being used in three sequential stages, and also to FIG. **4** which is a side elevational view of FIG. **1**.

In FIGS. **1—4**, the apparatus **10** is shown in its operating position attached to a putter **12** with the apparatus **10** and the putter **12** forming an assembly, generally designated **14**. The golfer is indicated at **16**, and in FIGS. **1—3** the golfer **16** is in the putting stance using the putter **12** and the apparatus **10** in executing a putting stroke. The putter **12** is, or may be, a conventional putter, and it comprises a shaft **18**, a handle or

hand grip portion **20** connected to an upper end portion **22** of the shaft **18**, and a putter head **24** attached to a lower shaft portion **26**.

The apparatus **10** comprises two elongate positioning members **28**, each of which has an upper body contact portion **30**, a lower putter connecting portion **32**, and an intermediate portion **34** extending between the contact portion and connecting portion **30** and **32**, respectively. The lower putter connecting portion **32** connects to a connecting section **36** which in turn connects the lower connecting portions **32** of the positioning members **28** to the lower shaft portion **26** of the putter shaft **18**. In this first embodiment, the position members **28** are shown as elongate rods or poles having sufficient length so that these are able to extend from the connecting section **36** upwardly and along the upper side torso portions of the golfer **16**.

One arrangement of this connecting section **36** is shown in FIGS. **5-8**. In this particular design of the connecting section **36**, there is a mounting portion **38** which is arranged to have a position adjustable rigid connection to the lower shaft portion **26**, and also a position member connecting portion **40** which connects the mounting portion **38** to the two lower putter connecting portions **32** of the two positioning members **28**.

In this particular arrangement, the mounting section **38** comprises a U-shaped bracket **42** (See FIG. **8**) having a middle portion **44** and first and second end portions **46** and **48** perpendicular to the middle portion **44**. The first end portion **46** is positioned to bear against the lower shaft portion **26**, and the second end portion **48** has a clamping screw **50** extending threadedly through a threaded opening in the second end portion **48**. The clamping screw **50** bears against a vertically aligned shaft engaging member **52** and has a vertical groove **54** to engage the lower shaft portion **26**. Thus, the clamping screw **50** is able to bear against the vertically aligned shaft engaging member **52** to clamp the mounting section **38** against the lower shaft portion **26**.

The positioning member connecting portion **40** comprises an intermediate connecting member **56** which has a lower end portion **58** pivotally mounted to the vertically aligned member **52** about a first axis of rotation at **60**. At the upper end of the intermediate connecting member **56**, there are two upwardly extending connecting ears **62** which are spaced from one another to define a slot-like opening aligned along a direction parallel to the axis **60**. Connecting to the lower end of each positioning member **28** is a connecting member **64** which fits between the two connecting ears **62** at a pivot connection, so that each of these can rotate about a respective one of two axes of rotation **66**.

Thus, it can be seen in FIG. **6** that the two positioning members **28** can rotate about their respective axes of rotation **66**, so that the upper end portions **30** of the positioning members **28** can be moved toward and away from each other pivotally with respect to the connecting section **36**. Also, it can be seen by observing FIGS. **5-7** that the two positioning members **28** can be moved pivotally toward and away from the shaft **18** about the pivot axis **60**.

The connecting section **36** can be selectively located at different locations along the shaft **18**, this being accomplished quite easily by loosening the positioning screw **50** and moving the connecting member **36** vertically, and then tightening the positioning screw **50**.

There will now be descriptions of the method of this first embodiment of the present invention. However, it is believed that before doing so, an understanding of the following text would be facilitated by providing a reference framework of the various features and functions.

In FIGS. **1** and **4**, the golfer **16** is shown in the putting stance with the assembly **14** of this first embodiment (comprising the apparatus **10** and the putter **12** connected to one another in the operating position). The term "forward" shall be used to denote the direction in which the golfer **16** is facing in executing the putting stroke as illustrated in FIGS. **1-4**, and the term "rear" or "rearward" shall denote the opposite. A lateral axis **70** shall be considered to be a horizontal axis extending perpendicular to a forward to rear axis **72** (see FIG. **4**), with this lateral axis being shown at **70** in FIGS. **1-3**. The forward to rear axis **72** is defined as a horizontal axis which extends in a forward to rear direction perpendicular to the axis **70**. The two axes **70** and **72** meet at a juncture location indicated at **73** and is between upper central portion of the torso or above the torso and the eye level of the person making the putt.

The first step in the method of this first embodiment, is to connect the apparatus **10** to the shaft **18**, and in this case the lower shaft portion **26** of the putter **18** by using the connecting section **36** in the manner described above, thus forming the assembly **14**.

The golfer **16** assumes his/her putting stance, such as shown in FIGS. **1** and **4**, for example, relative to a golf ball shown in FIGS. **1-3** at **74**. With the golfer's body in the putting stance, the golfer locates the positioning members **28** so that these extend upwardly from the connecting section **36** along a line that is generally vertical (with a moderate rearward and outward slant, depending on the putting stance of the golfer **16**), and so that the two upper contact portions **30** of the positioning members **28** are each located between the golfer's upper arm portions **76** of the arm **77** and the upper side portion **78** of the golfer's upper torso portion **80** at an upper contact region, the approximate upper location of which is indicated at **81**.

Then, the golfer **16** grasps the handle **20** of the putter **12**. The golfer **16** also presses his upper arm portions **76** inwardly toward the upper side portions **78** of his upper torso portion **80** so as to grip the upper body contact portion **30** of the related positioning member **28** to hold each upper body contact portion **30** of each positioning member **28** securely between the upper arm portion **76** and the upper side torso portion **78** at an upper contact location **81**.

With the shaft **18** of the putter **12** being pivotally connected to the two positioning members **28**, when the golfer first grips the putter, he golfer has the feel where in gripping the club, he has control of the movement of the club at the handle. Then when the golfer presses his/her upper arm portions **76** against the upper torso engaging portions **30** of the guide members **28**, the upper arm portions **76** become essentially stationary, so that the elbow location of the upper arm portions are stationary. Thus, when the golfer grips the hand grip portion of the putter **12** in a grip to execute the putting stroke, the forearms **82** of the golfer and his/her hand location remain substantially stationary with the upper torso portion of the golfer.

Also, as can be seen in FIGS. **1-4**, each of the positioning members **28** crosses over, and is in contact with, an upper portion of the golfer's forearm **82** at an approximate lower contact location **84** moderately below the location of the upper body contact portion **30** of the approximate positioning member **28** at the location **81**.

With the two positioning members **28** properly secured against the side portion of the person's torso and with the golfer's hands **85** grasping the handle **20** of the putter **18**, the golfer **16** (positioned in the putting stance) is now able to execute a proper putting stroke by which the putter head **24** travels in the back stroke away from the ball **74** by the golfer

rotating the entire upper body portion as a unit about the forward to rear axis **72** in a clockwise direction as shown in FIG. **2**, and the putter is then moved through the putting stroke with the golfer's upper body rotating in a counter-clockwise direction as seen in FIG. **3**.

As indicated earlier in this text, the present invention is designed to assist the golfer in developing and executing a putting stroke as described above, where the golfer's head and the lower part of the golfer's body (i.e., that is below the golfer's waist) remain substantially stationary throughout the putting motion, and the putting stroke is accomplished by the movement of the upper part of the person's body (including the person's arms) and the putter **12**, all functioning as a unit where the relative positions of the putter **12**, the apparatus **10**, and the golfer's upper torso, and the arms and hands are fixed with respect to one another.

To summarize certain features and to explain further how the method of the present invention is accomplished by using this apparatus **10** of the present invention, reference is made first to FIG. **1** which shows the golfer **68** in the putting stance with the golfer's head **86** looking downwardly toward the ball **74** along a line of sight **88** toward the ball **74**. The golfer is holding the putter **12** in a position where the shaft **18** is positioned in a vertical plane aligned in a forward to rear direction, with the shaft **18** extending in a downward direction and generally with a moderately forward slant (depending on the stance of the golfer **16**).

The positioning members **28** are connected at their lower ends to the connecting section **36** that is in turn connected to the shaft. These elongate positioning members **28** extend upwardly with a moderate rearward slant, and moderately outwardly from one another to engage the forearms **82** of the golfer at the location **84**, and the upper contact portions **30** being located between the golfer's upper arm portions **76** and upper side torso portions **78** at the upper contact locations **81**. The golfer presses his upper arm portions **76** laterally inwardly to firmly engage the upper body contact portions **30** of the positioning members **28** which are thus frictionally held between the upper arm portions **76** and upper side portions **78** of the person's torso. Also, this causes the golfer's two elbow portions to be held in a fixed location relative to the golfer's upper torso **80**.

At this point, let us examine the effect of the golfer **68** assuming this position with the assembly **14** (comprising putter **12** in the apparatus **10** connected to one another), as described immediately above and as shown in FIG. **1**. To illustrate this, reference is made to FIG. **4A** which shows schematically certain locations and components of the two positioning members **28**, the putter **12**, and the golfer's upper body.

We begin by recognizing that the pressure of the golfer's upper arm portions **76** at the contact location **81** (shown in FIG. **4A**) fixes the location of the upper body contact portion **30** of the positioning members **28** relative to the person's upper body portion (i.e., the upper torso **80**). Further, with the person pressing both upper arm portions **76** against the side portion of the person's upper torso portion **80**, the elbow location **90** at the lower end of each of the forearms **76** also becomes fixed relative to the person's upper torso portion **80**.

We now note that the two positioning members **28** which have their lower end portions connected at the location of the connector **36**, with the result being that we have structurally a rigid triangle frame with two of the end points being between the two contact locations **81** and the third end point at the connecting location at **36**. Therefore, the position of the connecting location at **36** relative to lateral movement

toward the right or left of the positioning members **28** is fixed, and the lower portion **26** of the shaft **18** at the location of the connecting location at **36** is also fixed, relative to the contact locations **81**.

Now, we look at the two elbow locations **90** which (as indicated above) are substantially fixed when the golfer **16** is pressing his upper arm portions **76** against the side of his torso **80**. The two forearms **82** extend downwardly and inwardly, with the person's hands **35** gripping the handle **20** of the golf club in a putting grip. Thus, we have two fixed locations at **90** and a third fixed location at the club handle **20** which form a substantially structurally rigid triangle. Therefore, with the two elbow locations **90** being fixed relative to the person's torso **80**, the upper hand grip portion **20** of the shaft **18** is also fixed relative to the person's torso and to the contact locations **81**.

Now, it becomes evident that if the person maintains the position shown in FIG. **1**, and with the person still pressing the upper arm portion **76** against the upper contact portions **30** of the positioning members **28** so that these upper contact portions **30** are pressed against a golfer's upper torso portion **80**, the only way that the putter head **24** can move right or left from the position of FIG. **1** is by causing a rotation of the upper body portion.

This rotation of the person's upper torso **80** can take place at about the location of the forward to rear axis **72** so that the putter head **24** moves approximately in a laterally aligned vertical plane, or rotate at a location above the axis **72** and closer to the golfer's head location.

To illustrate these relationships in a simpler form, reference is made to FIG. **4B**. For purposes of illustration, the width dimension of the location **81** has been expanded somewhat relative to the vertical dimension. The orientation of the shaft **18** of the putter **12** is determined by the two locations **20** and **36**. The lower location **36** is dictated by the positioning of the two positioning members **28**, which in turn are determined by the two fixed points **81**. Thus, if the two points **81** remain stationary, then there is no movement of the lower shaft location **36**, and if the two points **81** move, the lower shaft location **36** moves.

Likewise, the location **20** is determined by the two substantially fixed locations **90** which correspond to the location of the golfer's elbows which are substantially locked in place by the upper arm portions **78** pressing against the upper torso side portions and against the upper body contact portions of **30** of the positioning members **28**. Therefore, when the golfer rotates his/her upper torso about the forward to rear axis of rotation **72**, the entire substantially stationary structure comprising the points **81—81**, **90—90**, **20** and **36** rotate in a clockwise direction (for a right handed golfer) on the backstroke and then a counter-clockwise direction on the forward stroke of the putter head **24**. Thus, as the golfer moves from the position of FIG. **1** to that of FIG. **2**, the movement of the putter moves in a predictable manner controlled substantially entirely by the movement of the upper torso **80** of the golfer **16**. The same is true of the forward stroke from the position of FIG. **2** to the position of FIG. **3**.

Also, it is evident from viewing FIGS. **1—3** and also FIG. **4** that the upper intermediate portions of the positioning members rest on the golfer's forearms **82**. With the upper body contact portions **30** of the positioning members **28** being fixed to the upper side torso portions, the support provided by the forearms **82** engaging the positioning member **28** fixes the forward to rear location of the putter head **24** relative to the arms and torso of the golfer.

With regard to the relative dimensions and positioning of these significant locations as described above, with further reference to FIG. 4B, the distance from the top of the hand grip location at 20 to the connecting location at 36 (indicated at "a" in FIG. 4B) is in this embodiment about three times the distance from the connecting location 36 to the center of the putter head 24. Thus, if one considers the total distance (indicated at "c") from the hand location 20 to the putter head location 24 as 100%, then the distance "a" would be at about 75% or one quarter of the total length of the putter. Thus, if for some reason there would be a lateral movement at the hand location 20 of, for example, one inch with the positioning described above, the corresponding lateral movement of the putter head 24 would be about one-third of that distance (i.e., one-third of an inch).

Obviously, these relative dimensions could be changed, primarily by moving the location of the connecting location 36 further downwardly or upwardly along the putter shaft 18. For example, the connecting location 36 could be moved downwardly toward the putter head 24 so that this percentage would be 80%, 85%, 90%, or 95%. Likewise, it could be moved upwardly to a location of the connecting section 36 being at 70%, 65%, 60%, 55%, 50%, 45%, 40%, 35%, 30% or possibly smaller. This could be done, for example, to practice the putting stroke while focusing on certain components of the stroke. For example, if the connecting point 36 is moved upwardly closer to the location of the hand location 20, then this would cause greater restraint of the hand location relative to the lateral positioning of the putter head 24. Present analysis of the putting stroke would indicate that the distance from the connecting location 36 to the putter head 24 would be no greater than about one third or one-half of the total distance from the putter head 24 to the top of the hand grip location 20 for the normal operating mode when practicing the putting stroke. Further, by placing the connecting location 36 closer to the location of the putter head 24, movement of the putter head 24 relative to the person's upper torso would be more limited.

With the positioning members 28 in the position shown in FIGS. 1 through 4, the upper body contact portion 30 of the positioning member 28 extends at a downward and forward slant which is no greater than about one half of a right angle from vertical alignment and in a narrower range no greater than a third of a right angle, or a fourth or a fifth of a right angle, with this angle being illustrated at "a" in FIG. 4.

The second embodiment of the present invention is shown in FIGS. 9 and 10. Components of this second embodiment are similar to components of the first embodiment will be given like numerical designations with an "a" suffix distinguishing those in the second embodiment.

In FIG. 9, there are the two positioning members 28a and also the connecting section 36a. The positioning members 28a are made with three telescoping sections 91a, 92a, and 94a. Further, at the upper end of the upper telescoping section 91a there is an upper end covering member 96a which is made of a high friction material which is reasonably resilient so as to make the gripping of the upper contact portion more comfortable, and also to better secure the upper end contact portion 30a more effectively. In FIG. 10, the lower positioning member section 94a is shown having an end fitting 98a with a threaded male member 100a, which fits in a matching socket 102a so that the positioning member 28a can be removed from the connecting member 36a and placed in the collapsed position for storage.

FIG. 11 shows a third embodiment of the present invention. Components of this third embodiment which are simi-

lar to those of the first embodiment will be given like numerical designations with a "b" suffix distinguishing those of the third embodiment.

The positioning members 28b are contoured generally the same as in the first embodiment, except that at the location where the positioning members 28 crosses over the forearm 82 of the person, these are made with a raised curved portion as indicated at 104b, so as to fit the contour of the person's forearm 82.

FIG. 12 shows a fourth embodiment of the present invention. Components of this fourth embodiment which are similar to or the same as the first embodiment will be given like numerical designation with a "c" suffix distinguishes those of the third embodiment.

In this third embodiment, the positioning members 28c are essentially the same as in the first embodiment, except that at the upper end contact portions 30c of the positioning members 28c, the positioning members 28c have an end portion 106c at an angle slanted with respect to the lengthwise axis of the positioning member 28c, this being shown at 106c. In this particular embodiment, this slanted end portion 106c is extending in a curved upward and forward direction so that the curved portion is adjacent to (or in contact with) the portion of the person's anatomy between the upper back portion of the arm and the upper rear side torso portion. Obviously, the particular configuration of this end portion 106c could be modified.

A fifth embodiment of the present invention will now be described with reference to FIGS. 13, 14 and 15. Components of this fifth embodiment which are similar to components of the earlier embodiments will be given like numerical designations, with a "d" suffix distinguishing those of the fifth embodiment. The apparatus 10d comprises the two positioning members 28d having the upper torso contact portions 30d and lower putter connecting portions 32d by which the positioning members 28d are pivotally connected to the connecting section 36d. In this embodiment, the two positioning members 28d are each made as a pair of telescoping members 92d and 94d.

The contact portion 36d has a two part housing 110d having forward and rear housing sections connecting to each other, for example, by screws. The front housing portion 112d is shown in FIG. 13. In FIG. 15, the housing 110d has the front housing portion 112d removed, this being done to illustrate the connecting portion 36d. There are two pivot connections 114d, in the form of pins mounted to the rear housing portion. The two lower end connecting portions of the positioning members 28d pivotally connect to these pins 114d. In addition a pair of springs 116d are connected to these pins 114d and these engage the lower end portions of the two positioning members 28d to urge them toward one another in a closed position. These two springs 116d act against a pair of stubs 118d. The housing 110d is formed with upwardly facing slots through which the slots 120d through which the positioning members 28d extend.

There is a putter connecting device 122d which is fixedly mounted to the front housing portion 112d. This device 122d comprises two fingers 124d and 126d which are fixedly mounted to, and extend forwardly from the front housing portion 112d. These two fingers 124d and 126d define a slot 128d that is slightly narrower than the diameter of the putter shaft 16d. Also, the slot 128d is formed with a moderately narrowed entry portion 130d. These two fingers 124d and 126d are made of a relatively stiff rubber-like material that is able to grip the putter shaft and retain it in the slot 128d. Yet these fingers 124d and 126d are sufficiently yielding so that the putter shaft would be able to rotate slightly. Thus, the

golfer in grasping the grip portion of the putter would still have the feel of having control of the putter at the hand grip portion so he would have a certain amount of back and forth movement of the putter while it is still held by the fingers **124d** and **126d**.

The mode of operation of this fifth embodiment is substantially the same as the earlier embodiments, in that the putter is connected to the connecting portion **36b** by being placed in the slot, defined by the fingers **124d** and **126d**. The upper torso connecting portions **30d** of the positioning members **28d** are positioned between the golfer's upper arm portions and the golfer's torso in the manner described above. Then the putting stroke is executed in the same manner as described previously in this text.

Various modifications can be made to the present invention without departing from the basic teachings thereof.

I claim:

1. A method of assisting a golfer to improve the golfer's ability to utilize a putter in a putting stroke, with the putter comprising a shaft having a shaft upper end portion at which there is a hand grip portion and a putter head at a lower shaft end portion, and the golfer having a torso comprising an upper torso portion with two upper torso side portions, two arms with each arm comprising an upper arm portion, a forearm portion, and a hand, said method comprising:

- a) providing an apparatus comprising two elongate positioning members, each comprising an upper positioning member torso engaging portion, a lower positioning member connecting portion and a positioning member intermediate portion;
- b) connecting the positioning member connecting portions of the positioning members to the putter at a connecting location or locations below the hand grip portion;
- c) positioning the upper positioning member torso engaging portions of the positioning members at the upper torso side portions of the golfer, with the golfer then pressing the golfer's upper arm portions toward the upper torso side portions in a torso engaging position to hold the upper positioning member torso engaging portions in place at the upper torso side portions of the golfer;
- d) the golfer gripping the hand grip portion of the putter in the golfer's hands, with the golfer's upper arm portions in the torso engaging position, with the result that the golfer's upper torso portion, arms and hands are at substantially stationary locations relative to one another and the putter is at a substantially stationary position relative to the golfer's upper torso;
- e) the golfer executing a putting stroke by moving the golfer's upper torso relative to a lower portion of the golfer's body.

2. The method as recited in claim **1**, further comprising providing a connecting section which is connected to the putter shaft and to the lower positioning member connecting portions of the positioning members.

3. The method as recited in claim **2**, wherein the connecting section is vertically adjustable in its position on the shaft.

4. The method as recited in claim **3**, further comprising providing the lower positioning member connecting portions of the positioning members to be moveable angularly relative to the connecting section.

5. The method as recited in claim **1**, further comprising providing the lower positioning member connecting portions of the positioning members to be moveable angularly relative to the connecting section.

6. The method as recited in claim **2**, wherein both lower positioning member connecting portions are connected at substantially the same location along the length of the shaft.

7. The method as recited in claim **6**, wherein the lower positioning member connecting portions are pivotally connected on the shaft.

8. The method as recited in claim **7**, wherein said pivot connections are provided as universal pivot connections.

9. The method as recited in claim **8**, wherein said putter is removably connected to the connecting section.

10. The method as recited in claim **9**, wherein said connecting section is provided as a resilient gripping member defining a retaining slot to receive said shaft so that said shaft is removably connected to the connecting member.

11. The method as recited in claim **1**, wherein the golfer positions his/her arms are positioned relative to the positioning members so that the golfer's forearms are in engagement with the positioning members.

12. The method as recited in claim **11**, wherein said positioning members are provided in a contoured configuration so as to define a contoured portion thereof arranged to engage the forearms of the golfer.

13. The method as recited in claim **1**, wherein the upper positioning member torso engaging portions are when engaged by the upper arm portions aligned so as to have a downward and forward slant relative to a vertical line no greater than about half a right angle.

14. The method as recited in claim **1**, wherein the lower positioning member connecting portions connect to the shaft of the putter at a location that is no higher than about two thirds of the length dimension of the putter from the putter head.

15. The method as recited in claim **14**, wherein the lower positioning member connecting portions connect to the shaft of the putter at a location that is no higher than about on half of the length dimension of the putter from the putter head.

16. The method as recited in claim **1**, wherein the lower positioning member connecting portions are connected to the shaft at a location no higher than about one third of the length of the shaft of the putter from the putter head.

17. The method as recited in claim **1**, wherein each of said positioning members is provided as a plurality of telescoping members which can be extended or contracted relative to one another.

18. The method as recited in claim **1**, wherein at least one of said positioning members has an upper end portion extending beyond upper positioning member torso engaging portions and in a direction behind a back portion of the golfer's torso.

19. A method of assisting a golfer to improve the golfer's ability to utilize a putter in a putting stroke, with the putter comprising a shaft having a shaft upper end portion at which there is a hand grip portion and a putter head at a lower shaft end portion, and the golfer having a torso comprising an upper torso portion with two upper torso side portions, two arms with each arm comprising an upper arm portion and a forearm portion, and a hand, said method comprising:

- a) providing an apparatus comprising two elongate positioning members, each comprising an upper positioning member torso engaging portion, a lower positioning member connecting portion and a positioning member intermediate portion;
- b) connecting the positioning member connecting portions of the positioning members to the putter at a connecting location or locations below the hand grip portion;

11

c) positioning the upper positioning member torso engaging portions of the positioning members at the upper torso side portions of the golfer, with the golfer then pressing the golfer's upper arm portions toward the upper torso side portions in a torso engaging position to hold the upper positioning member torso engaging portions in place at the upper torso side portions of the golfer;

d) the golfer gripping the hand grip portion of the putter in the golfer's hands, with the golfer's upper arm portions remaining in the torso engaging position, with the result that the golfer's upper torso portion, arms and hands are at substantially stationary locations relative to one another and the putter is at a substantially stationary position relative to the golfer's upper torso, and with the positioning member intermediate portions being in contact with forearm portions of the golfer;

e) the golfer executing a putting stroke by moving the golfer's upper torso relative to a lower portion of the golfer's body portion.

20. An apparatus for assisting a golfer to improve the golfer's ability to utilize a putter in a putting stroke in a manner that the apparatus is used by the golfer in a use position while the golfer is gripping the putter in a putting stance while executing the putting stroke, with the putter comprising a shaft having a shaft upper end portion at which there is a hand grip portion and a putter head at a lower shaft end portion, and the golfer having a torso comprising an upper torso portion with two torso side portions, two arms with each arm comprising an upper arm portion and a forearm portion, and a hand, said apparatus comprising:

a) two elongate positioning members, each comprising an upper positioning member torso engaging portion, a lower positioning member connecting portion and a positioning member intermediate portion;

b) a connecting section to which the connecting portions are pivotally connected and which has a putter con-

12

necting portion arranged to be removably connected to the putter at a location below the hand grip portion of the putter;

c) said positioning members being arranged so that in the use position said upper positioning member torso engaging portions of the positioning members are able to be positioned at the upper torso side portions of the golfer, in a manner that the golfer is able to press the golfer's upper arm portions toward the upper torso side portions to press the upper positioning member torso engaging portions in place at the upper torso side portions of the golfer, with the positioning members having sufficient length so that with the golfer in the putting stance and gripping the hand grip portion of the putter in the use position in the golfer's hands, and with the golfer's upper arm portions remaining substantially stationary relative to the upper torso of the golfer, the connecting section is connected to the putter at a location below the hand grip portion of the putter, whereby the golfer is able to execute a putting stroke by moving the golfer's upper torso relative to a lower portion of the golfer's body, with the golfer's upper torso portion, arms and hands being at substantially stationary positions relative to one another and the putter being at a substantially stationary position relative to the golfer's upper torso.

21. The apparatus as recited in claim **20**, wherein the connecting section has a connecting position which is vertically adjustable on the shaft.

22. The apparatus as recited in claim **20**, wherein the connecting of the apparatus connected to the putter so that there is an apparatus/putter assembly arranged to be used by the golfer in executing the putting stroke.

* * * * *