



US007111856B1

(12) **United States Patent**  
**Graham**

(10) **Patent No.:** **US 7,111,856 B1**  
(45) **Date of Patent:** **Sep. 26, 2006**

(54) **BIPEDAL MOTION ASSISTING METHOD AND APPARATUS**

(76) Inventor: **Gary Graham**, P.O. Box 5146, Glacier, WA (US) 98244

(\* ) Notice: Subject to any disclaimer, the term of this patent is extended or adjusted under 35 U.S.C. 154(b) by 0 days.

(21) Appl. No.: **10/960,364**

(22) Filed: **Oct. 6, 2004**

**Related U.S. Application Data**

(60) Provisional application No. 60/567,046, filed on Apr. 29, 2004, provisional application No. 60/509,195, filed on Oct. 6, 2003.

(51) **Int. Cl.**

**B62M 1/00** (2006.01)  
**B62B 5/06** (2006.01)  
**A61H 3/00** (2006.01)

(52) **U.S. Cl.** ..... **280/87.021; 280/304.5; 135/67**

(58) **Field of Classification Search** ..... 280/87.05, 280/42, 250.1, 62, 304.1, 282, 87.021, 304.5; 482/68, 67, 66; 297/5, 6, DIG. 4; 188/109, 188/29, 74; 135/67, 66

See application file for complete search history.

(56) **References Cited**

**U.S. PATENT DOCUMENTS**

1,307,058 A 6/1919 McGrath  
2,316,100 A \* 4/1943 Nelson ..... 280/87.05  
2,654,416 A \* 10/1953 Maniscalco ..... 188/109  
2,843,180 A \* 7/1958 Schwartz ..... 482/68  
2,847,057 A \* 8/1958 Holcombe ..... 482/68  
4,159,110 A \* 6/1979 Dodenhoff ..... 482/68

4,226,413 A \* 10/1980 Daugherty ..... 482/67  
4,239,248 A 12/1980 Ewers  
4,312,505 A 1/1982 Engelhart  
4,510,956 A \* 4/1985 King ..... 482/68  
D281,771 S \* 12/1985 Webb ..... D12/130  
4,813,664 A 3/1989 Vroulis  
4,907,794 A 3/1990 Rose  
5,020,560 A \* 6/1991 Turbeville ..... 280/304.1  
5,378,215 A 1/1995 Harkins  
5,676,388 A 10/1997 Bertani  
6,070,603 A \* 6/2000 Politz ..... 280/304.1  
6,220,612 B1 4/2001 Beleski  
6,296,263 B1 10/2001 Schultz  
6,554,302 B1 4/2003 Liu  
6,743,156 B1 \* 6/2004 Jacques et al. .... 482/68

**FOREIGN PATENT DOCUMENTS**

DE 3620378 A \* 12/1987  
GB 2127705 A \* 4/1984

**OTHER PUBLICATIONS**

Catalogue Advertisement: Get Post-Op Clients Back on Their Feet with the Eva Support Walker, p. 149-156, Published in United States.

\* cited by examiner

*Primary Examiner*—Hau Phan

(74) *Attorney, Agent, or Firm*—Michael F. Hughes; Hughes Law Firm, PLLC

(57) **ABSTRACT**

A mobile support system having a central region that allows the legs to move in an unobstructed manner and providing an upper body support assembly where the weight is distributed between the elbow region and hand region of the individual for a desirable weight distribution for assisted bipedal motion such as walking or running.

**16 Claims, 17 Drawing Sheets**

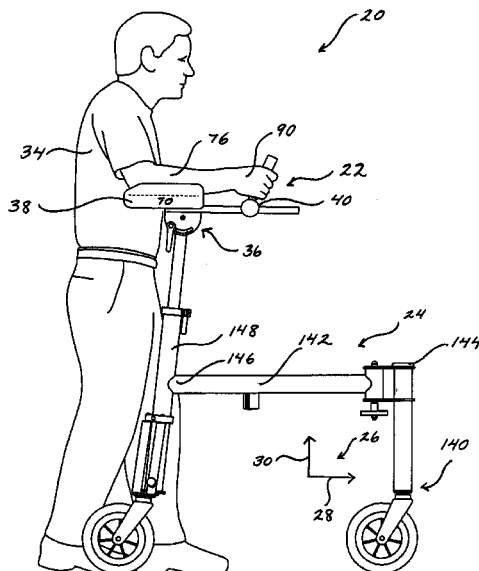

FIG. 1

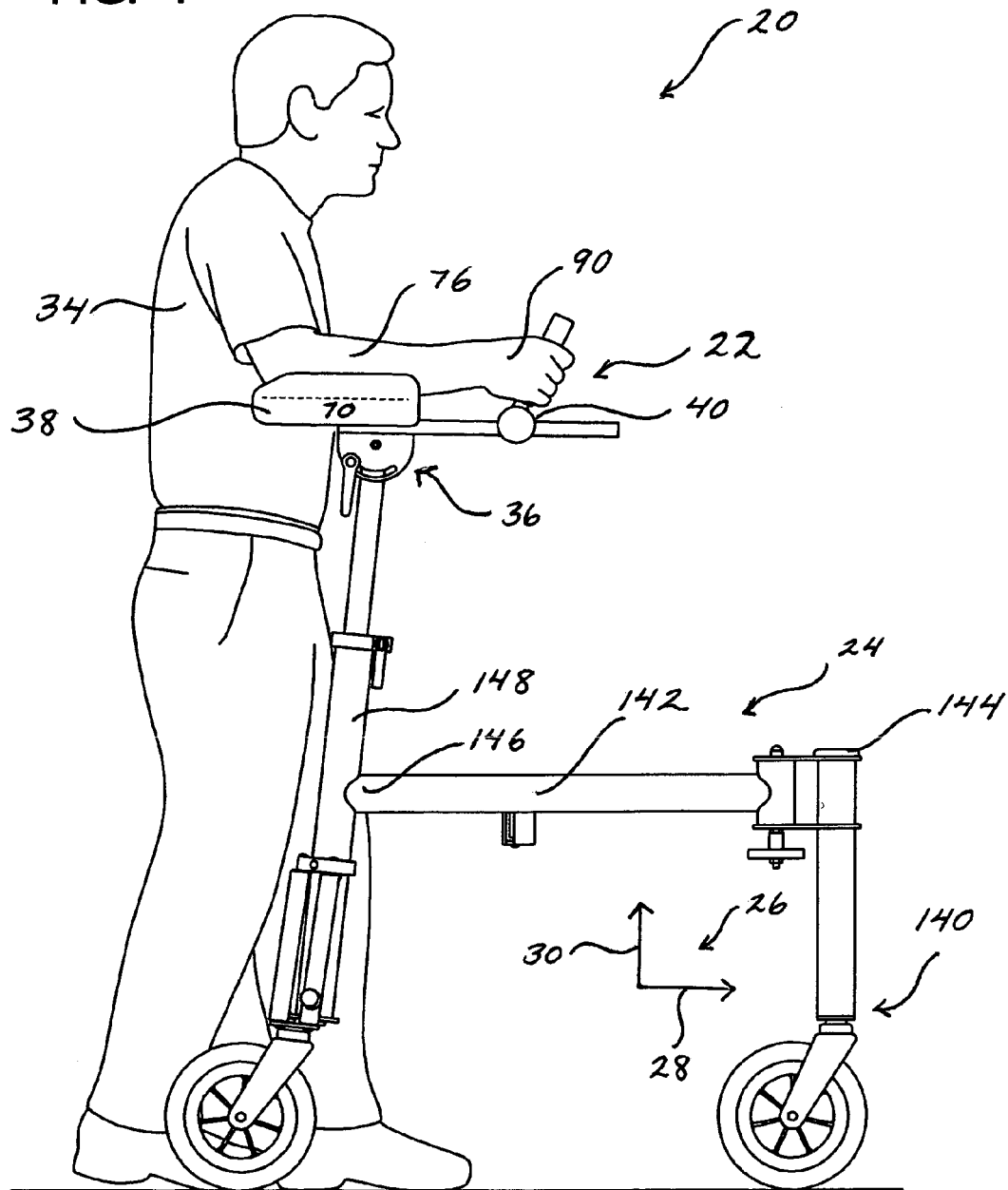
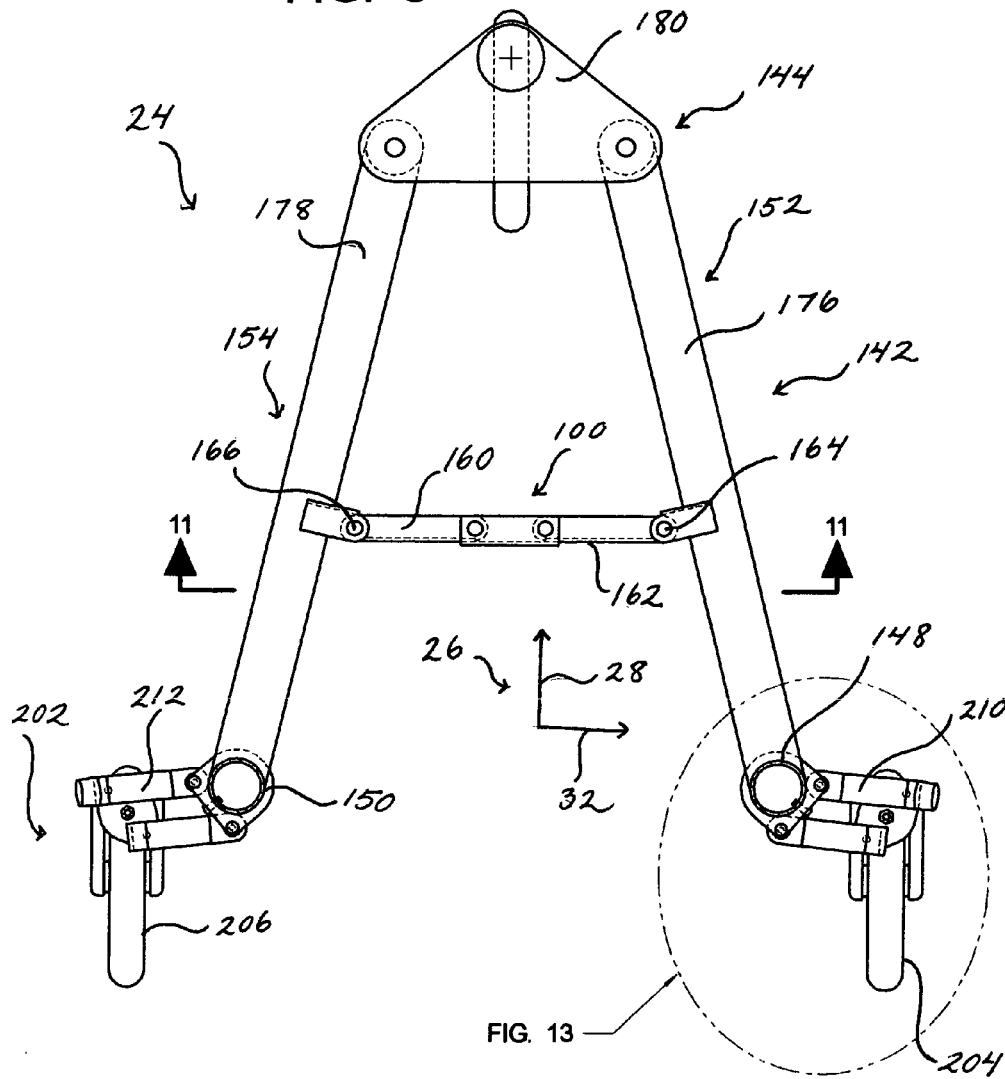
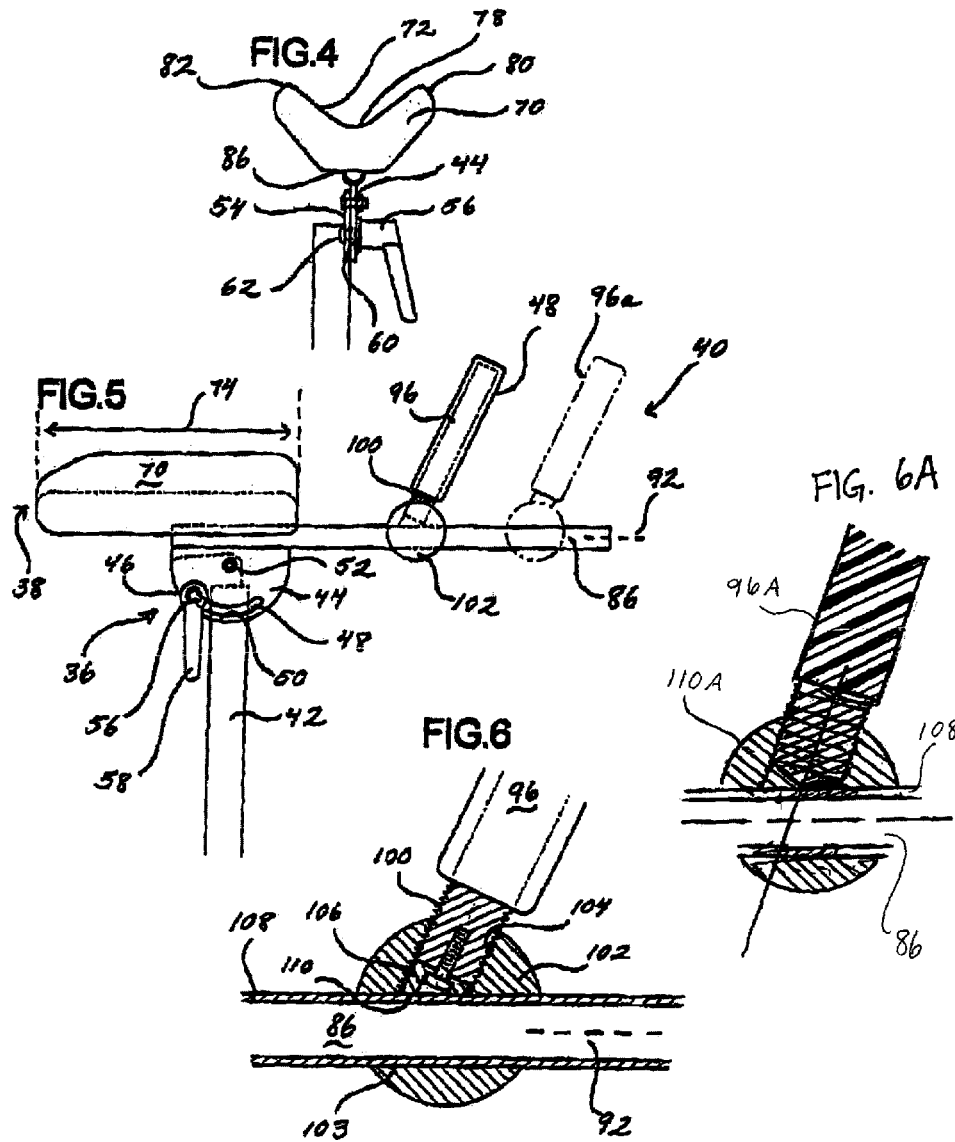
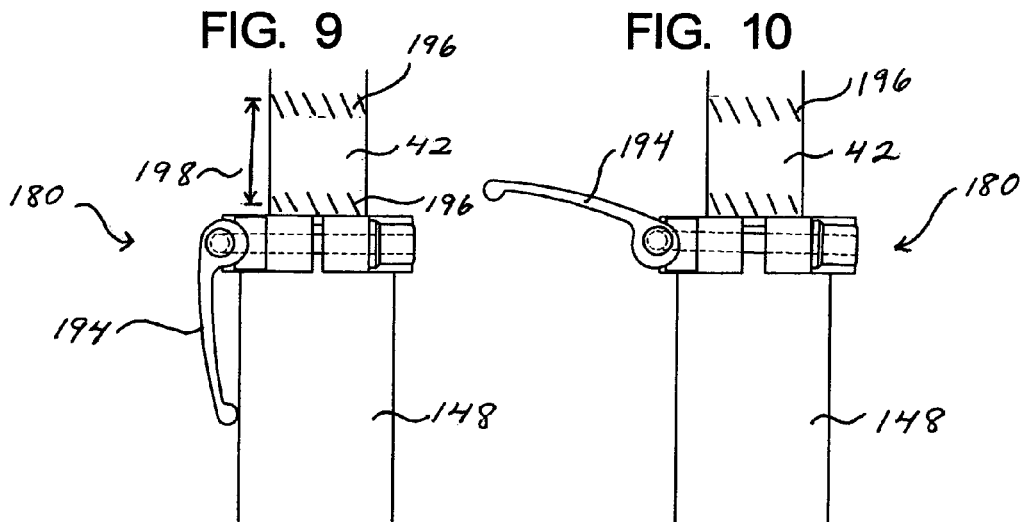
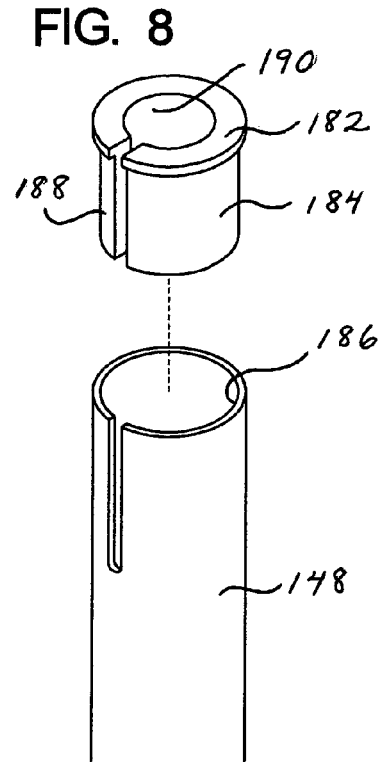
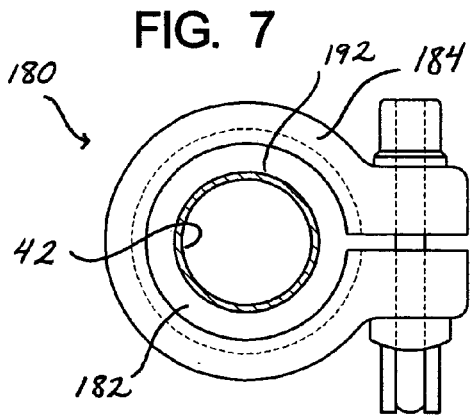

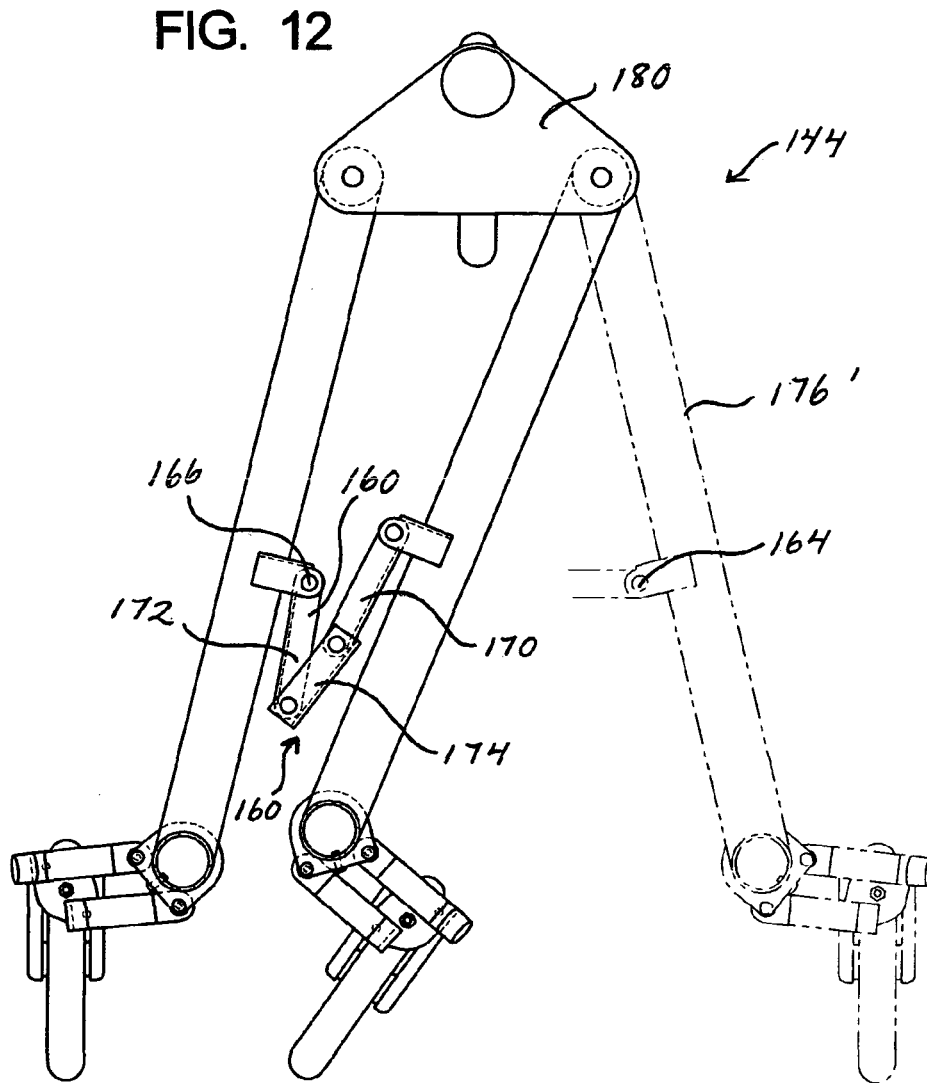
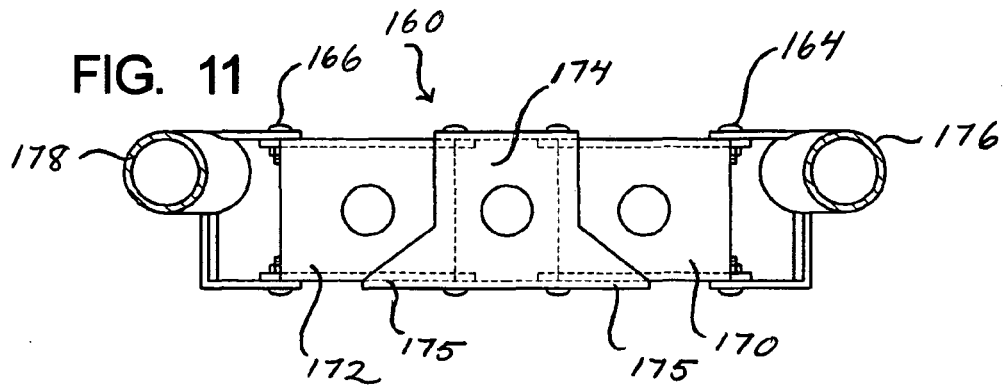

FIG. 3









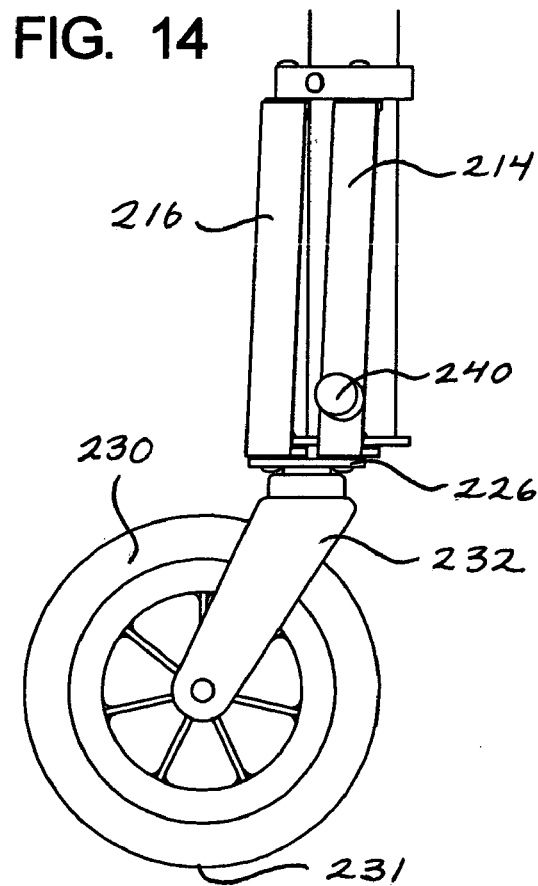
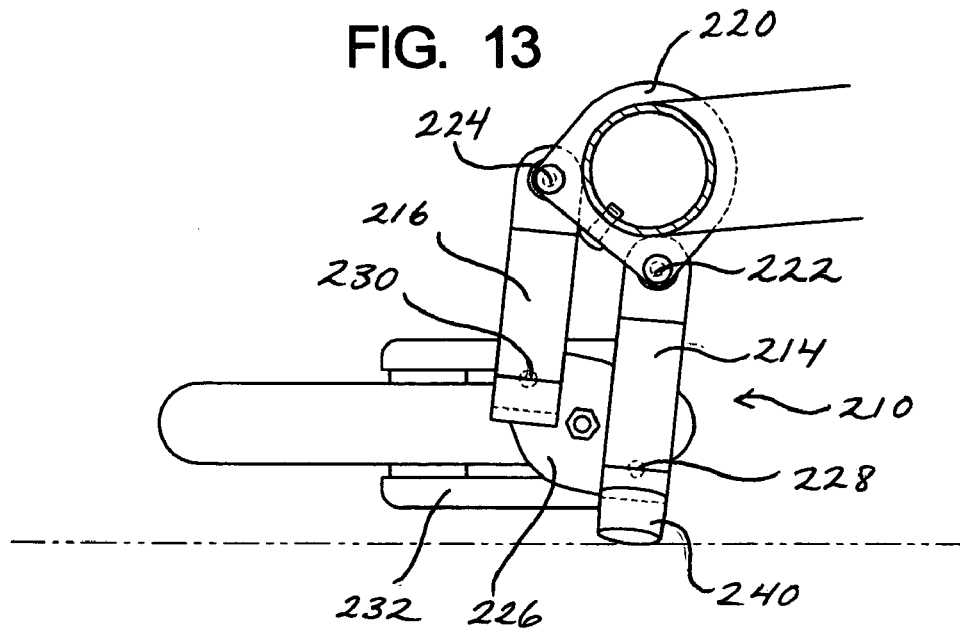

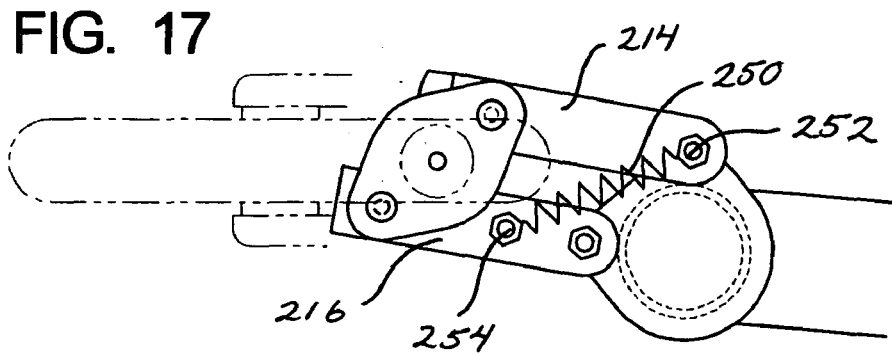
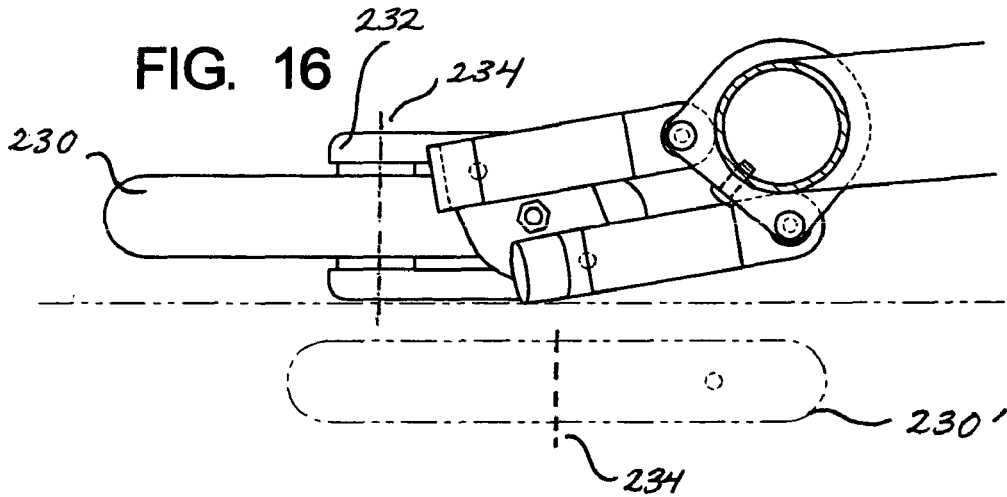
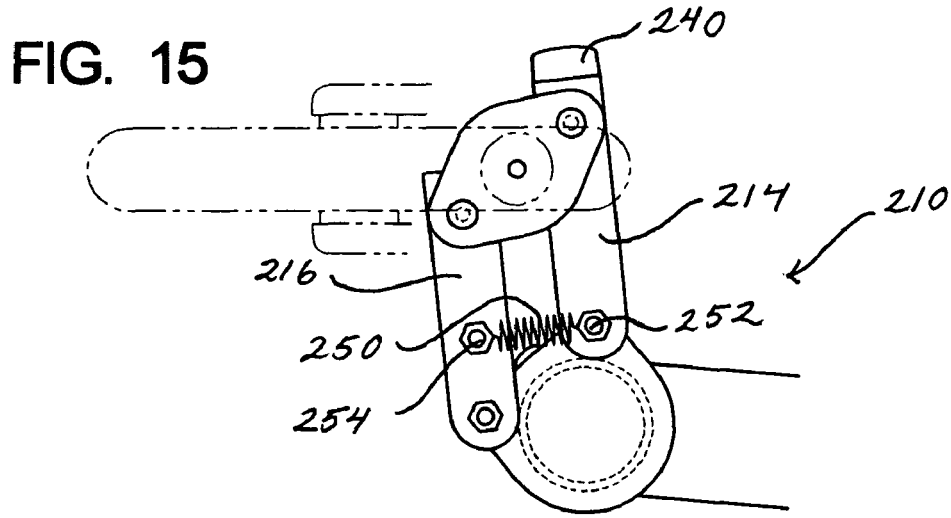

FIG. 18

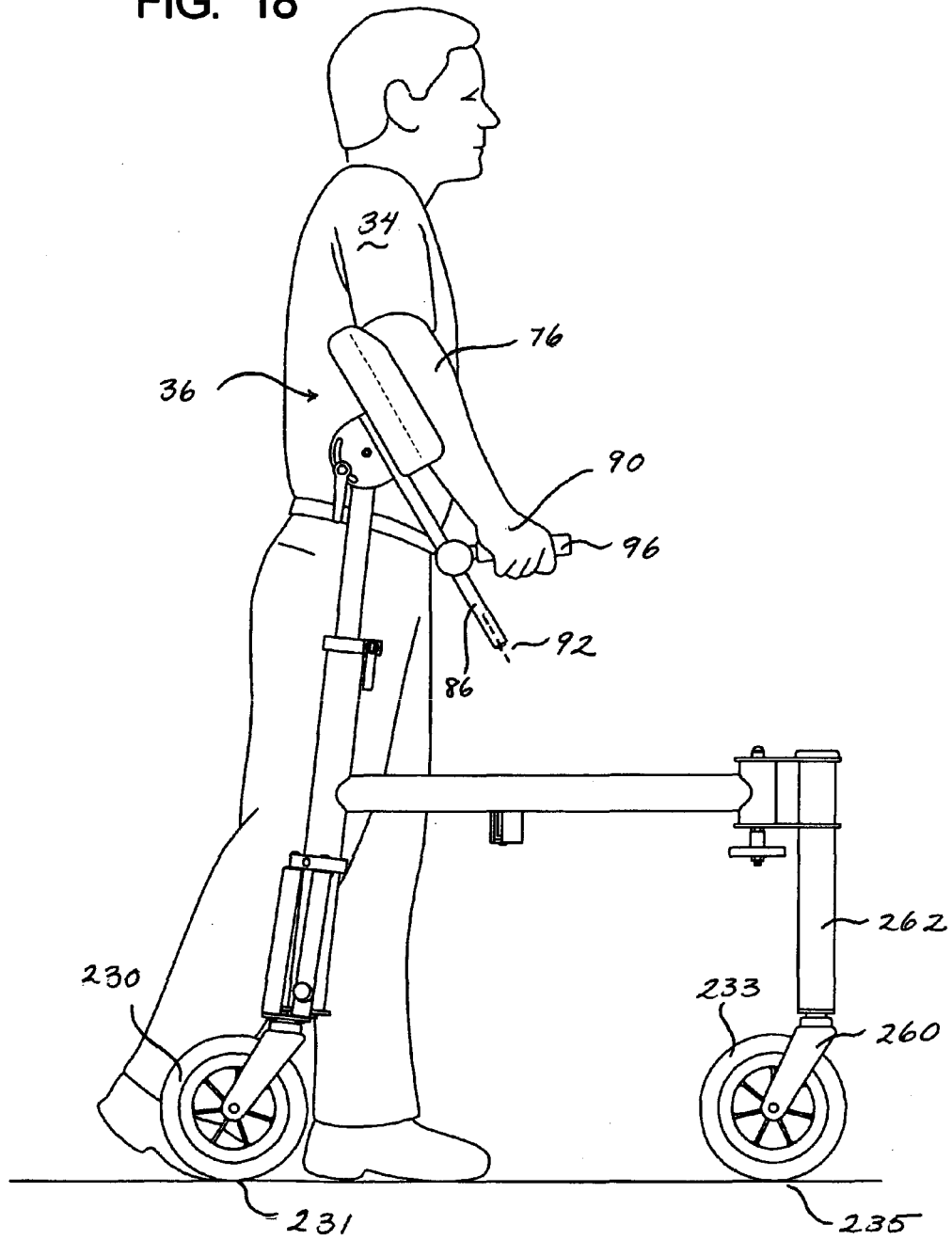

FIG. 19

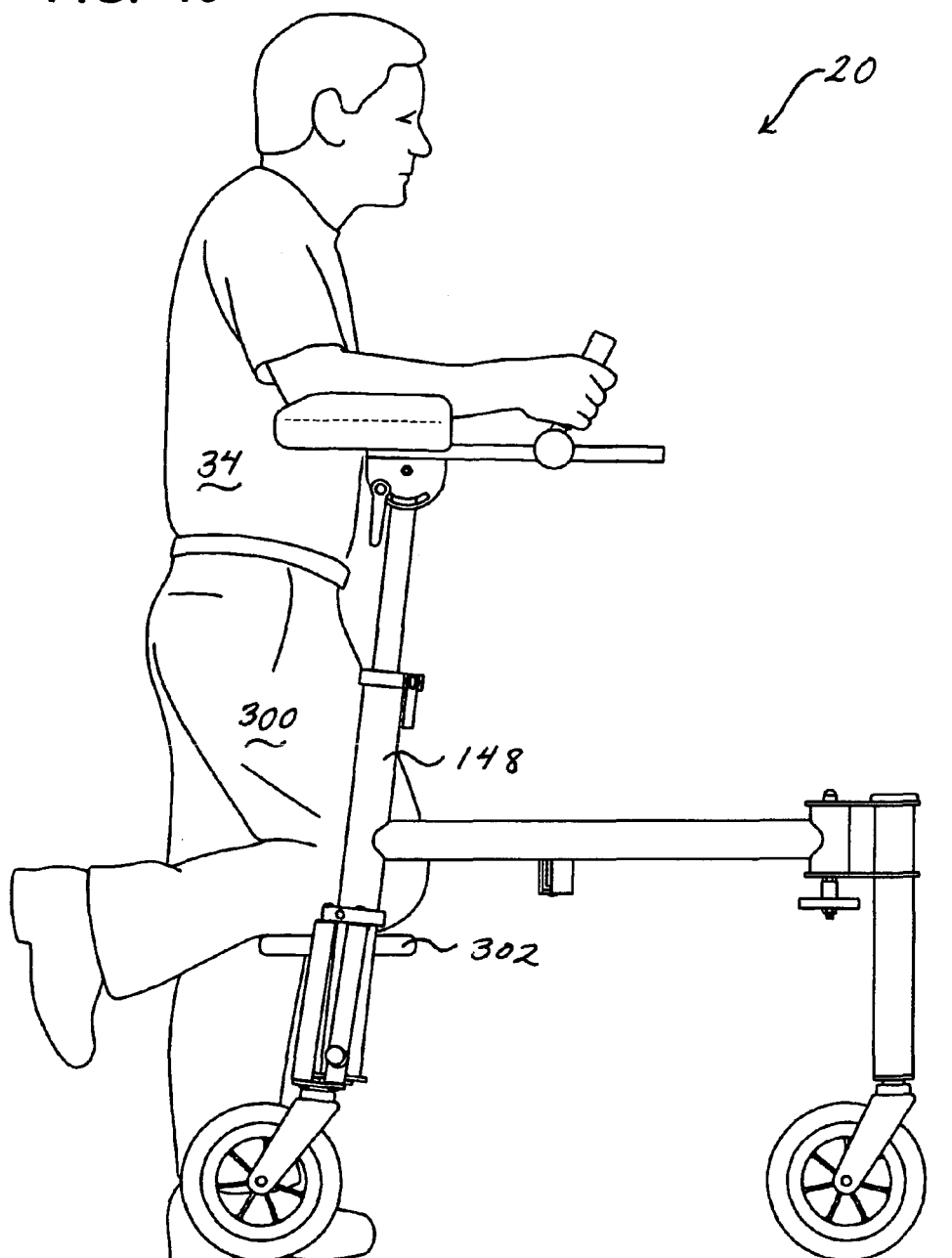

FIG. 20

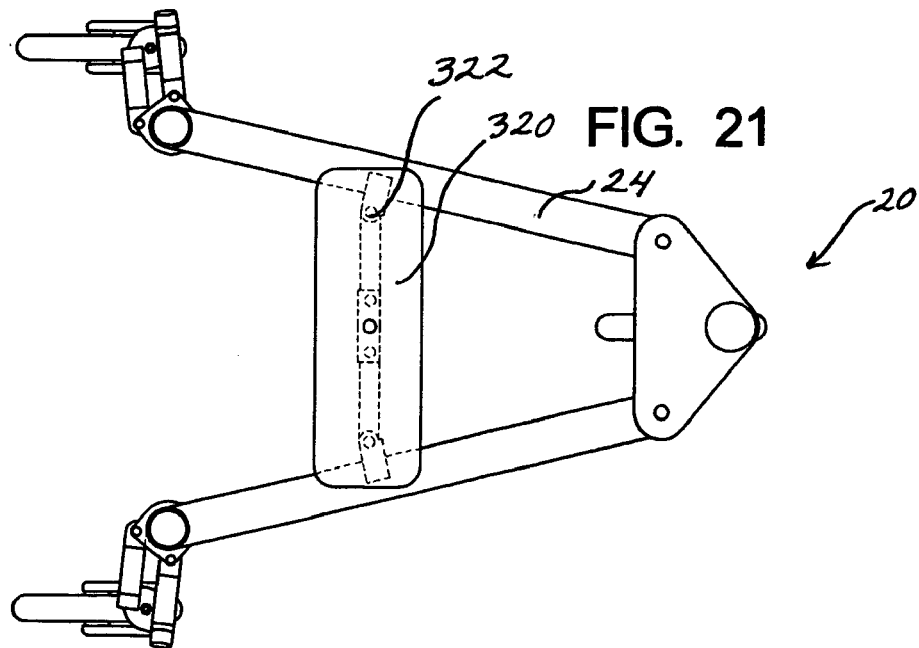
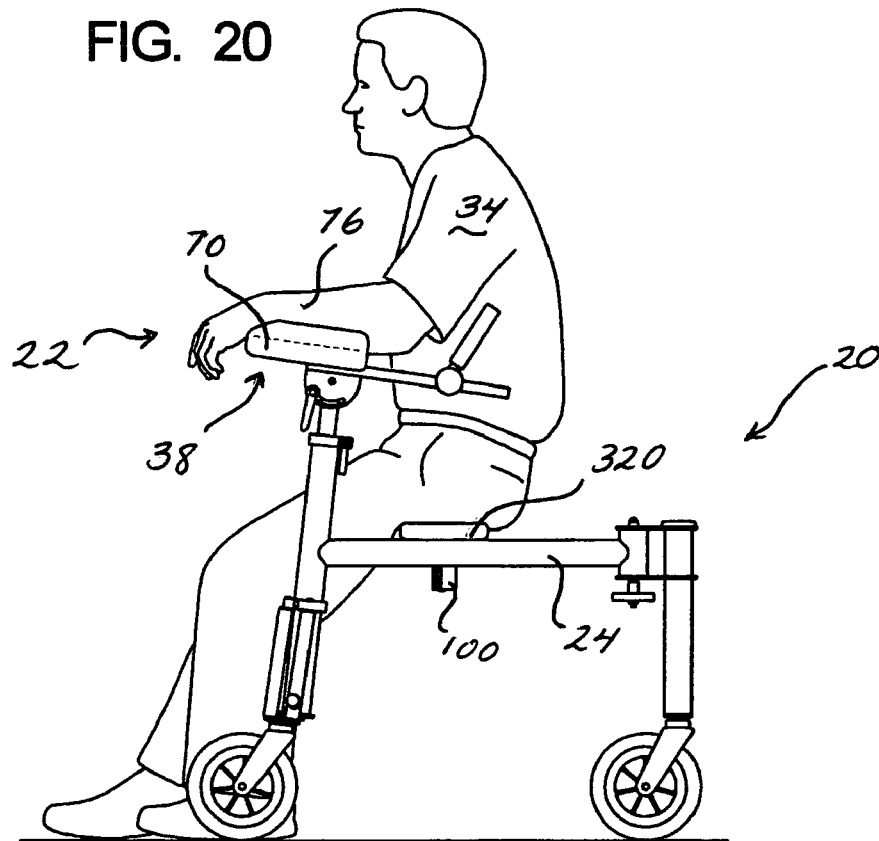

FIG. 22

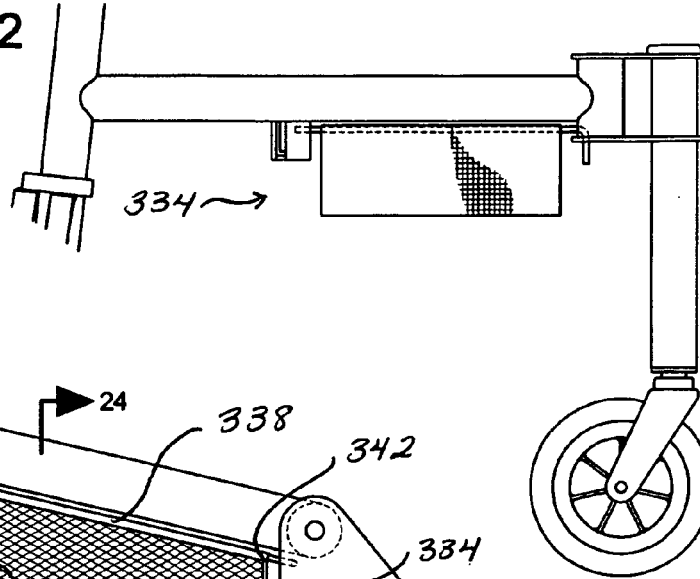

FIG. 23

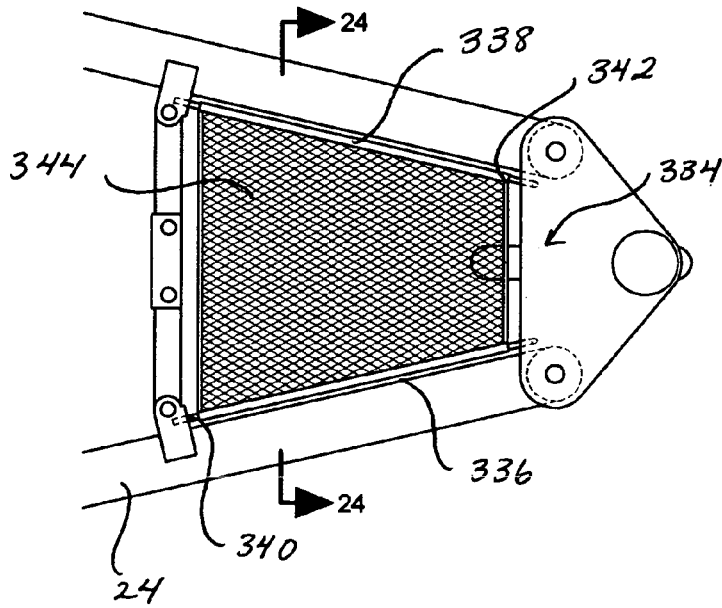

FIG. 24

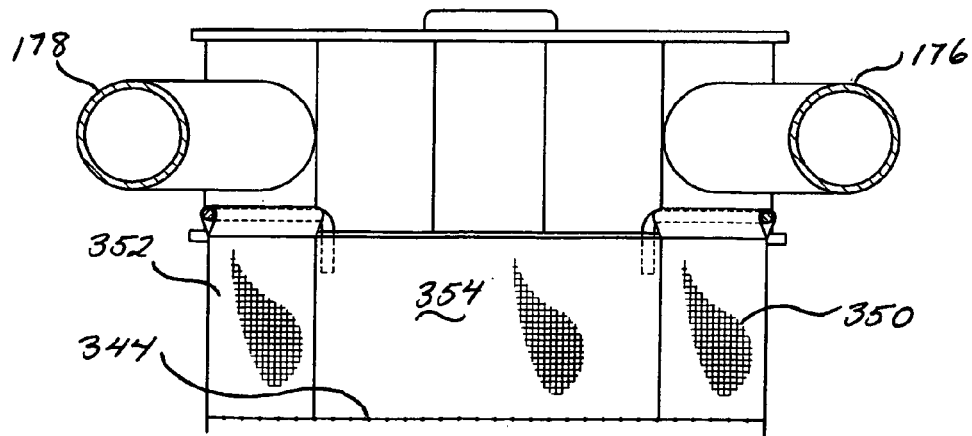

FIG. 25

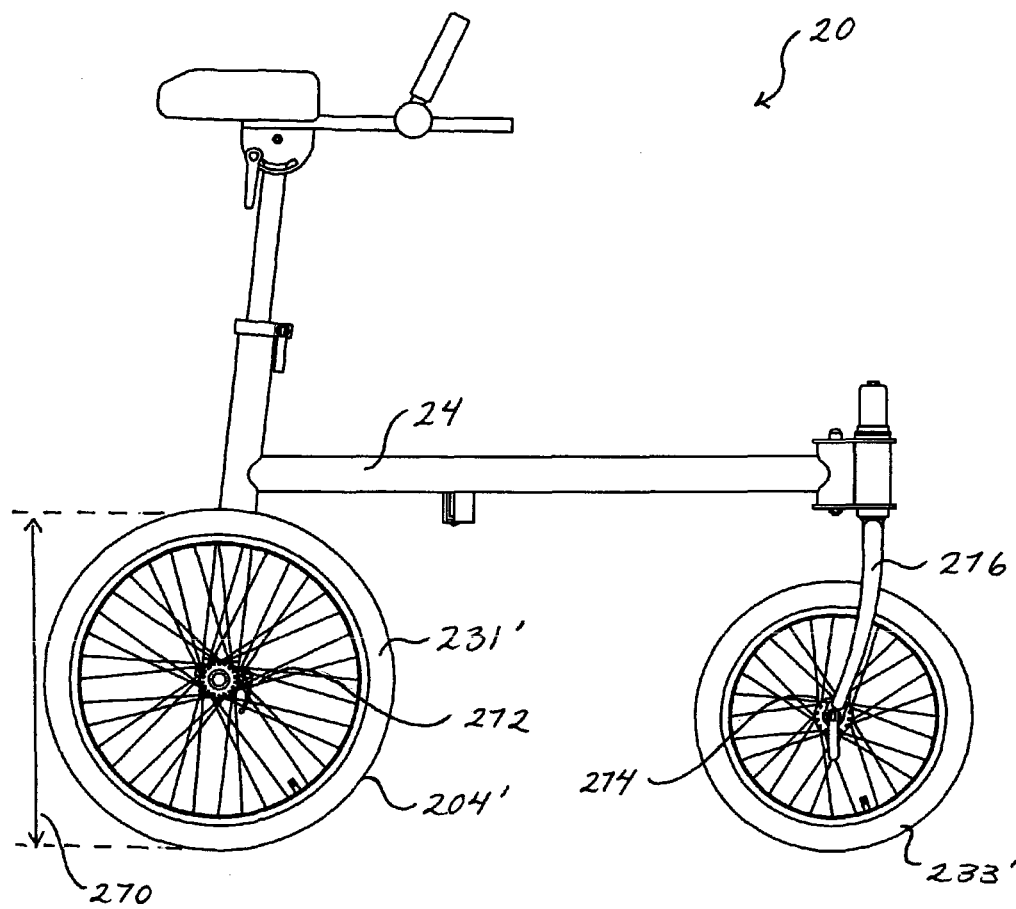

Fig. 26

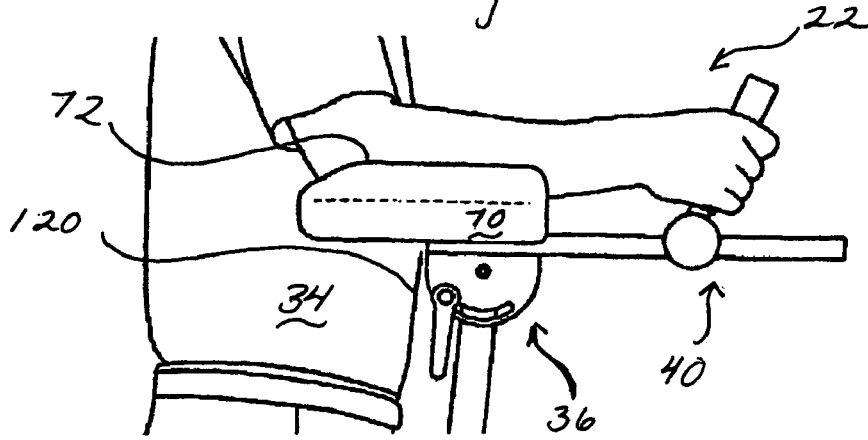
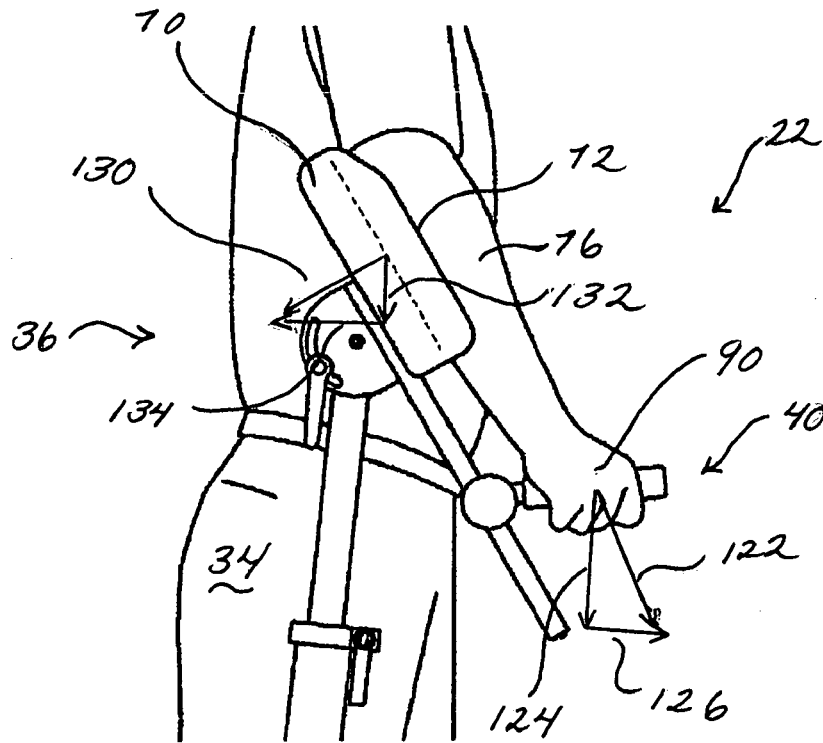
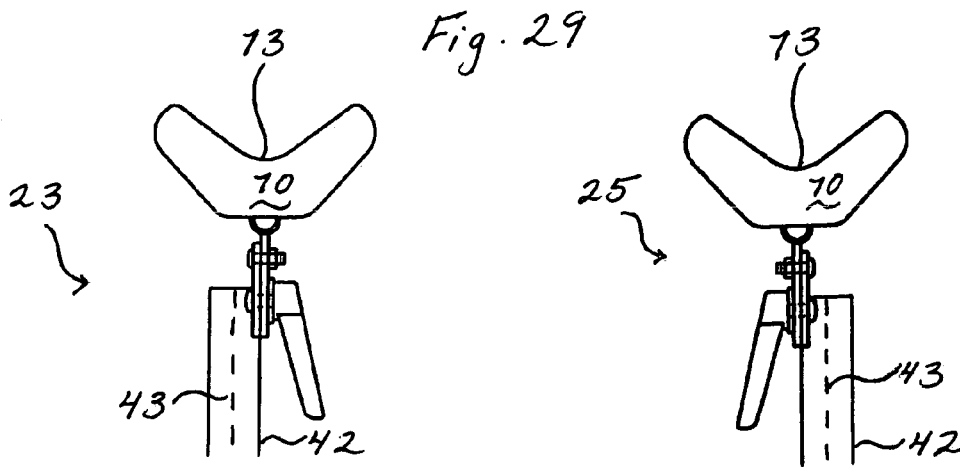
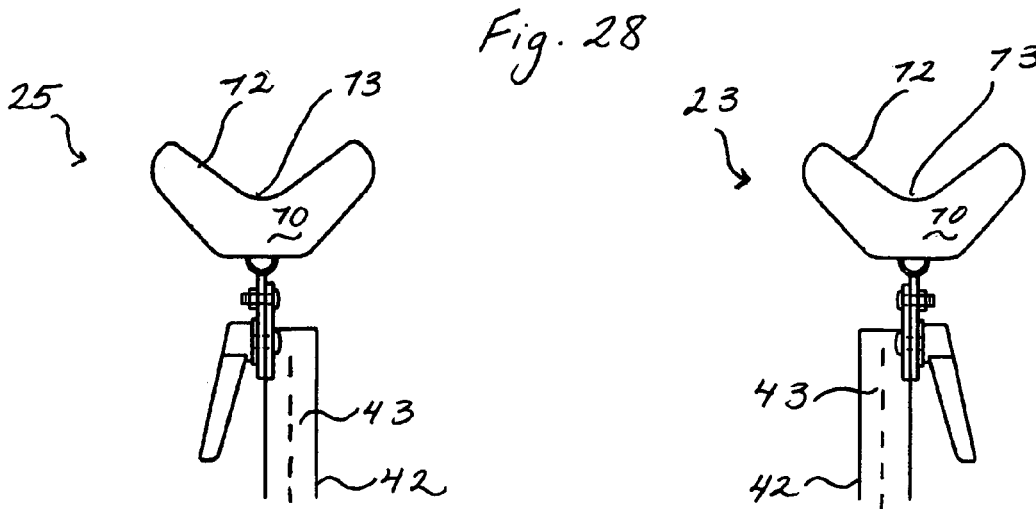
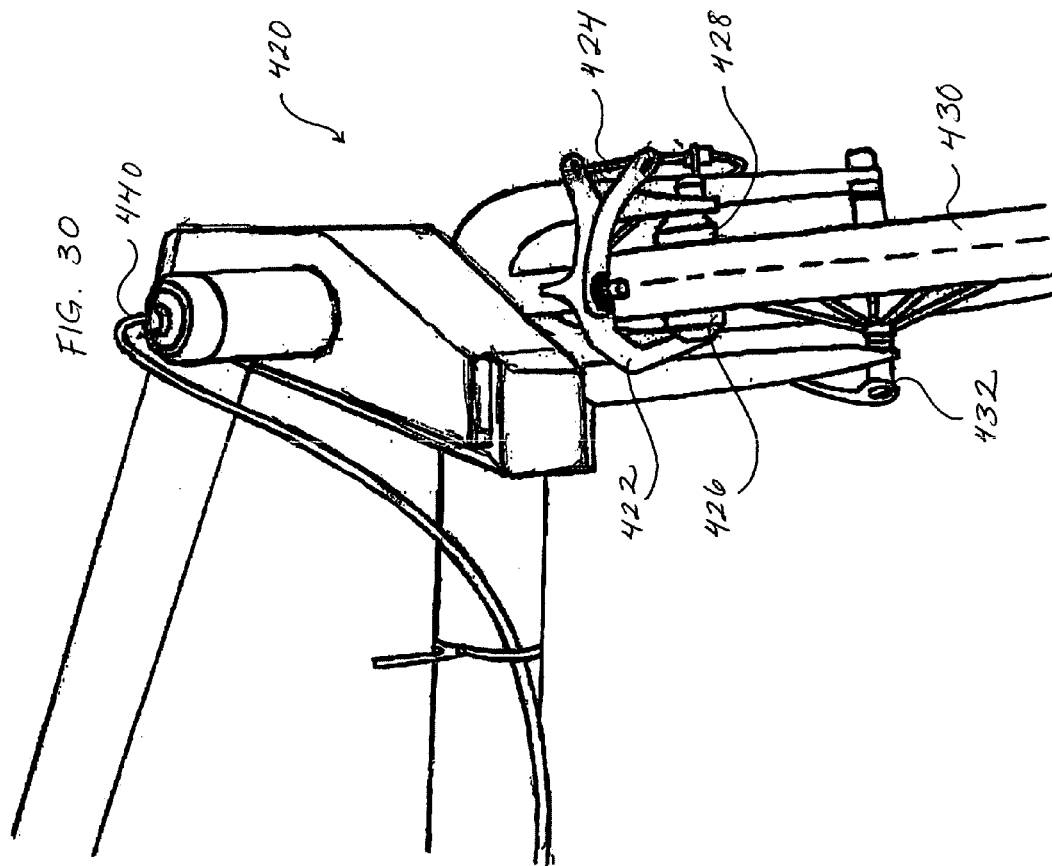
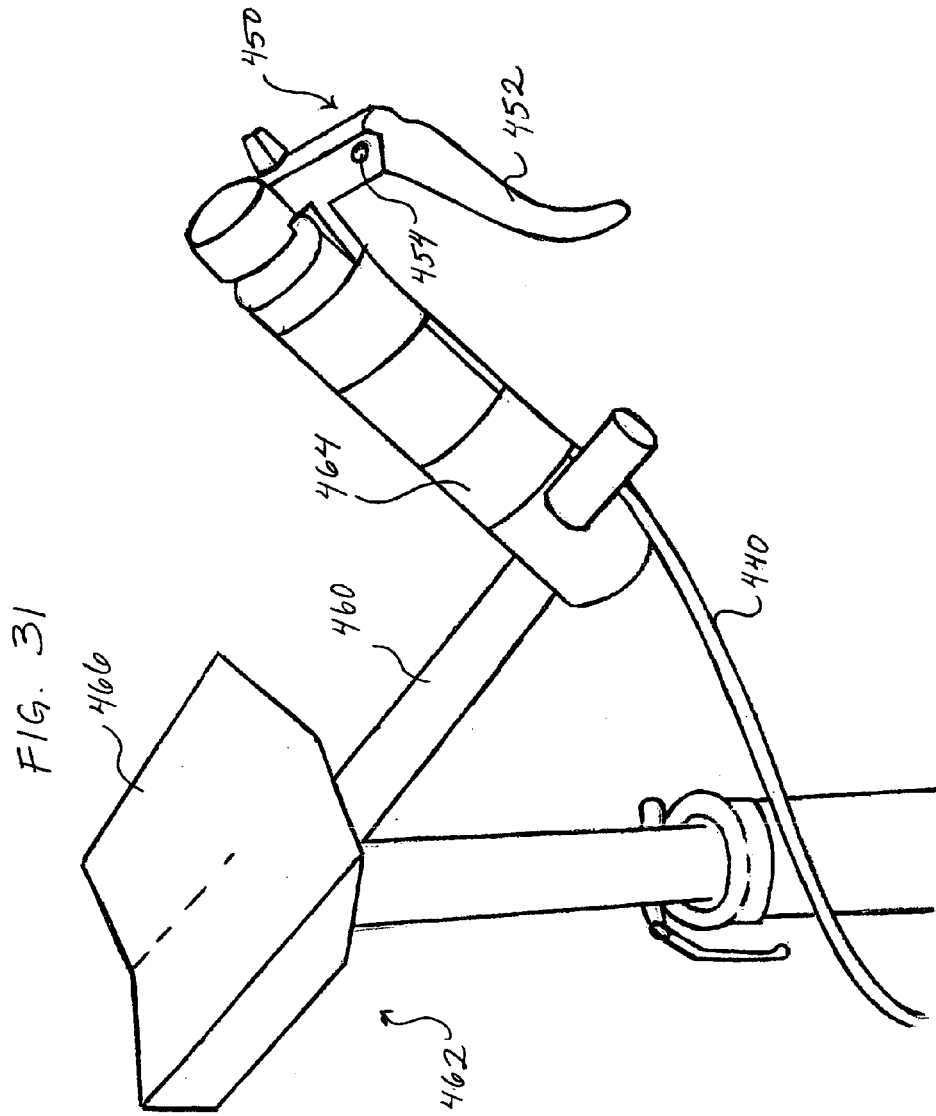

Fig. 27









## BIPEDAL MOTION ASSISTING METHOD AND APPARATUS

### RELATED APPLICATIONS

This application claims priority benefit of U.S. Ser. No. 60/509,195, filed Oct. 6, 2003, and U.S. Ser. No. 60/567,046, filed Apr. 29, 2004.

### BACKGROUND OF THE INVENTION

The area of use related to the apparatus shown below is to assist various individuals in bipedal motion such as walking and running. The apparatus shown below is particularly conducive for individuals that desire an active lifestyle but have mobility issues such as troubled joints or other ailments that do not allow them to fully support their own body weight upon their legs for the duration of time.

The apparatus shown below is particularly conducive for allowing the individual to run in that the weight of the individual is partially supported by the elbows and hands of the individual. Further, the center of gravity of the individual with respect to the support system is such that it is very desirable and comfortable for the individual to walk at a brisk pace or run and alter the amount of force distributed upon the upper body support system. The apparatus is particularly distinctive in that it does not have the appearance or functional feel of a clinical hospital-type device, but rather is very conducive overall to an active lifestyle.

In general, the prior art devices that are adapted to assist an individual conduct bipedal motion are not conducive for an individual with a more active lifestyle. These prior art devices utilize cumbersome structures that are not adequate to support the upper body of an individual.

### SUMMARY OF THE INVENTION

This invention relates to a mobile support system having a longitudinal and lateral axis adapted to support an individual having a leg and right elbows and left and right hands. The mobile support system comprises a base frame which has a first lateral frame member and a second lateral frame member, the first and second lateral frame members forming a central unobstructed region adapted to provide free motion of the leg of the individual.

The mobile support system also comprises a wheel assembly attached to the base frame, which has a longitudinally rearward wheel subassembly and a longitudinally forward wheel subassembly, where the longitudinally rearward wheel subassembly comprises first and second longitudinally rearward wheels each having ground engagement locations, the longitudinally forward wheel subassembly having a ground engagement location that is positioned laterally between the ground engagement locations of first and second longitudinally rearward wheels.

In addition, the mobile support system comprises an upper body support assembly attached to the base frame, the upper body support assembly having an elbow support region comprising first and second elbow supports adapted to support the left and right elbows of the individual, and also having a support handle assembly comprising first and second support handles adapted to be grasped by left and right hands.

In addition, the body weight of the individual is adapted to be partially supported by the upper body support assembly whereby a portion of the weight is distributed to the

elbow support region and a portion of the weight is distributed to the support handle assembly.

### BRIEF DESCRIPTION OF THE DRAWINGS

FIG. 1 is a side view of the mobile support system 20 with an individual utilizing the system;

FIG. 2 is a side view of an embodiment of the mobile support system;

FIG. 3 is a top view of the mobile support system;

FIG. 4 is a rearward view taken at line 4—4 in FIG. 2 showing the upper body support assembly of the mobile support system;

FIG. 5 is a side view of the upper body support assembly showing various positions of the support handle assembly;

FIG. 6 is a partial sectional view of the intermediate locking member illustrating a method of locking and adjusting the support handle of the support handle assembly;

FIG. 6A shows another embodiment of the handle whereby in one form, the handle is a unitary item which can be plastic injected molded and the forward region has a conical or frustoconical obtuse angled surface to engage the outer surface of the base region of the upper body assembly;

FIG. 7 is a partial sectional view of the locking mechanism adapted to adjust the upper body support assembly with respect to the base frame;

FIG. 8 is a partial exploded view of a sleeve insert adapted to engage the base post of the base frame and adjustably fix the extendable post of the upper body support assembly;

FIG. 9 is a side view of the locking mechanism in a locked position;

FIG. 10 is a side view of the locking mechanism in an adjustable position;

FIG. 11 is a sectional view of the laterally extending support member taken at line 11—11 in FIG. 3;

FIG. 12 is a top view of the mobile support system shown in a stored orientation;

FIG. 13 is a sectional top view taken at line 13—13 of FIG. 2 showing the first laterally inward displacing device;

FIG. 14 is a side view of the laterally inward displacing device shown in a laterally outward orientation;

FIG. 15 is a partial schematic bottom view looking upwardly illustrating the first laterally inward displacing device orientated in a laterally outward orientation with the forward and rearward linkages positioned partially in the lateral direction;

FIG. 16 shows the first laterally inward displacing device in a laterally inward position;

FIG. 17 shows the first laterally inward displacing device from a bottom view where the biasing member is extended in a retracted position and adapted to reposition the forward and rearward linkages to an orientation as shown in FIG. 15;

FIG. 18 shows the mobile support system in an orientation where the pitch adjustment system has adjusted the upper body assembly orientation in a manner where a greater percentage of the load from the individual exerted thereon is distributed to the support handle;

FIG. 19 shows an alteration whereby a limb support is provided to support the lower limb of the individual;

FIG. 20 shows another modification whereby the mobile support system has a seat attachment that is in one form attached to the laterally extending support member and is adapted to support an individual;

FIG. 21 is a top view of the mobile support system with the seat attachment attached thereto;

FIG. 22 shows another variation whereby a basket area is provided and is adapted to hold objects and personal items therein;

FIG. 23 is a top view of the basket region;

FIG. 24 is a sectional view taken at line 24—24 of FIG. 23 showing the basket area cross-sectionally;

FIG. 25 shows another embodiment of the mobile support system whereby larger all-terrain wheels are provided;

FIG. 26 shows one angle of usage of the upper body support assembly;

FIG. 27 shows another possible orientation of the upper body support assembly;

FIG. 28 shows one embodiment of the left and right elbow support members;

FIG. 29 shows another orientation of the left and right elbow support members where they are essentially exchanged in position to provide greater or narrower lateral width so as to accommodate a wide variety of individuals;

FIG. 30 is an isometric view of a braking system that can be employed in the front tire of the mobile support system;

FIG. 31 shows a handbrake system that can be employed in conjunction with the braking system as shown in FIG. 30.

#### DETAILED DESCRIPTION OF THE PREFERRED EMBODIMENTS

Other prior art devices that support individuals for bipedal motion have employed a system for either providing vertical support on the hands or the armpit region in a similar manner as crutches. This method of support is wholly inadequate for long-term vertical support for the individual.

It should be noted that the directions forward and rearward relating to the longitudinal direction and lateral indicating a side-to-side direction are general indicators, and given the rotational nature of many of the components, moving in one direction may vector components in other directions. In other words, if a component repositions in the laterally inward direction, of course there may be other movement vectors such as in the longitudinal or perhaps vertical direction. The ground as discussed herein is any solid portion of the earth such as (but not limited to) pavement, interior flooring, outdoor dirt trails, etc.

As shown in FIG. 1, there is a mobile support system 20, the mobile support system comprising an upper body support assembly 22 and a base frame 24. An axis system 26 is defined whereby the axis 28 defines a longitudinal axis and the axis 30 indicates a vertical axis. Further, referring to FIG. 3, a lateral axis 32 is defined and is substantially orthogonal to axes 28 and 30. The arrow of the axis 32 indicates a first lateral direction pointing laterally outwardly and the opposite direction is defined as a second lateral direction.

The mobile support system 20 in general is adapted to assist an individual 34 to engage in bipedal motion with a certain degree of assistance. The individual in one form can be an elderly person that is not adapted to travel long distances by way of bipedal motion with either running or walking. Or alternatively, the individual 34 may be a person with some form of temporary injury who requires a certain degree of mobile assistance, or any other individual otherwise requiring or desiring some mobile support. The embodiments of the present invention are particularly conducive for a lightweight extremely mobile and comfortable system having a sportier design conducive for individuals 34 that desire to have a certain degree of activity.

The upper body support assembly comprises a first support member 23 and a second support member 25 (see FIG. 28). As shown in FIG. 2, the 1st and 2nd support members

(only the first support member is visible in FIG. 2) are adapted to be received by the base post 148 of the base frame 24. The upper body support assembly 22 comprises a pitch adjustment system 36, an elbow support region 38, and a support handle assembly 40. The pitch adjustment system 36 as shown in FIG. 5 comprises an extendable post 42 and a rotation plate 44. Further, the pitch adjustment system 36 comprises a locking member 46. The rotational plate 44 in one form comprises a partially circular annular slot 48 having a perimeter region 50 immediately adjacent to the annular slot 48 and having a surface bearing substantially in the lateral direction. The rotational plate 44 further comprises a pivot region 52 which in one form is a laterally extending pin of some sort or a nut and bolt assembly adapted to have the rotational plate 44 rotate therearound. As shown in FIG. 4, the rotational plate 44 is positioned adjacent to a base plate 54 that is fixedly connected to the extendable post 42. The locking member 46 in one form comprises an engagement member 56 having a handle region 58. The engagement member 56 is a standard frictional engagement type, and as shown in FIG. 4, has a laterally inward surface 60. As further shown in FIG. 4, the laterally extending pin 62 engages the baseplate 54 where the rotational plate 44 is interposed and frictionally and temporarily positioned between the baseplate 54 and the laterally inward surface 60. Therefore, by rotating and applying a torque to the handle region 58, the rotational plate 44 can be rotationally and fixedly positioned which has an effect on the load distribution between the elbows 76 and hands 90 of the individual 34 (see FIGS. 1 and 18) as described further herein. Of course other locking mechanisms such as any kind of pins, slots and extensions or other means that are foreseeable can be employed to rotate the pitch of the upper body support assembly 22.

The elbow support region 38 comprises first and second elbow pads. A first elbow pad 70 is shown in FIGS. 4 and 5. Referring to FIG. 4, the first elbow pad (which is similar to the second elbow pad except symmetrical about the center plane of the mobile support system extending in the vertical and longitudinal directions) comprises an upper contact surface 72. As shown in FIG. 5, the elbow pad 70 has a longitudinal length 74 that is sufficiently long to distribute the load along the elbow and upper forearms 76 of the individual 34 as shown in FIG. 1. As shown in FIG. 4, the upper surface 72 has a central vertically lower region 78, a first lateral upper region 80, and a second laterally upper region 82. The regions 78, 80 and 82 are of a concave nature to support the elbow and upper forearm 76 of the individual (see FIG. 1). The lower portion of the elbow pad 70 is fixedly attached to the base region 86. The longitudinal length dimension 74 can roughly extend between 4 inches and 12 inches in one form and a more preferred range of about 8 inches in length.

Now referring ahead to FIGS. 26 and 27, a force diagram is shown where the orientation of the upper body support assembly 22 in FIG. 26 produces a resultant force vector 120 somewhere along the upper contact surface 72 of the elbow pad 70. The support handle assembly 40 provides some control over the mobile support system and various loads can be exerted thereto. For example, if the individual 34 loses his or her balance rearwardly, he/she can supply a vertical force to counteract such loss of balance and the weight of the mobile support system is used to help the individual regain his footing. Further, the support handle assembly 40 also allows for lateral turning left and right by supplying a slight rotational torque about a vertical axis of the mobile support system.

Now referring to FIG. 27, a force vector 122 is shown where the vector 122 is comprised of a substantially vertically downward component 124 and a forward component 126. The vectors 124 and 126 are orthogonal to one another and are used as an analytical tool to help define our analysis. It is clear from FIG. 27 that the load exerted upon the upper body support assembly 22 has now drastically changed whereby the pitch adjustment system 36 has now distributed a substantial amount of vertical load 124 upon the support handle assembly 40. Now referring to the upper left-hand portion in FIG. 27, it can be seen that a schematic force vector 130 is positioned on the elbow pad 70. Assuming the upper contact surface 72 has a sufficiently low coefficient of friction with the skin of the forearm 76 of the individual 34, the resultant vector 130 will be substantially orthogonal to the surface 72. Therefore, the force vector 130 can be broken down to its orthogonal components 132 and 134. Therefore, it can be appreciated that if the forearm 76 is to remain static, the forward force vector 126 is approximately equal to the rearward force vector 134. It can further be appreciated that the force 132 supplying the vertical load (as well as the resultant force 130) is less than the downward force 120 as shown in FIG. 26. Therefore, the pitch adjustment system 36 allows for a redistribution of the load between the hand region 90 and the upper forearm/elbow region 76 of the user 34. This is particularly useful in a situation where the user 34 desires to redistribute the load exerting upon the mobile support system in a different manner due to the forearm skin becoming sore or any other reason. It can further be appreciated that the dynamic of the motion of the individual is somewhat changed when the upper body support assembly 22 is in the orientation as shown in FIG. 27. For example, the center of gravity of the individual 34 is positioned in a somewhat more forward region in FIG. 27. Further, the orientation of the upper body support assembly 22 in FIG. 27 is more conducive for an upright walking posture with the shoulders rotated to a more rearward position. Therefore, the user 34 or therapist can utilize the mobile support system in a manner to achieve desired walking posture for bipedal motion which is conducive for recovery from an accident or other reasons which impeded the walking and running of an individual 34.

FIGS. 28 and 29 illustrate another element of flexibility of arranging the components of the mobile support system in one form. The orientation of the first and second support members 23 and 25 is such that the upper support surface 72 has a center valley region 73 that is positioned slightly laterally outwardly from the vertical center lines 43 of the extendable post 42. This arrangement of the first and second support members 23 and 25 is conducive for an individual who has broader shoulders or a wider girth or otherwise desires a wider elbow positioning.

Now referring to FIG. 29, it is shown that the first and second support members 23 and 25 have switched positions within the first and second base posts of the base frame. Therefore, the center valley regions 73 are positioned laterally inwardly with respect to the orientation as shown in FIG. 28, and this orientation is more conducive for an individual with narrower shoulders or otherwise desiring a narrower positioning of the elbow pads 70.

The support handle assembly 40 as shown in FIG. 5 in general is adapted to support and provide a force to the hands 90 of the individual 34 (see FIG. 1). It is desirable to have the support handle assembly adjustable to accommodate positioning and orientation of the forearm 76 of the individual 34. Further, in one form the support handle assembly is adapted to be rotated about the central axis 92

of the base region 86 as shown in FIG. 5. In general, the central axis 92 extends substantially in the longitudinal direction and in a desirable form slightly laterally inwardly and vertically downwardly in the forward region to ergonomically fit the individual 34. The support handle assembly 40 comprises a support handle 96 having an outer surface 98 adapted to be grasped by the individual 34 as shown in FIG. 1. As further shown in FIG. 5, the support handle 96 has a lower region 100 that is adapted to engage an intermediate locking member 102. In one form the support handle 96 is threadedly engaged to the intermediate locking member 102. As shown in FIG. 6, the lower portion 100 has a threaded outer surface and the locking member 102 has a female receiving threaded surface 104. A frictional engagement member 106 is attached to the lowermost region of the lower portion 100. The base region 86 has an outer surface 108 that in one form is cylindrical and adapted to engage the partially cylindrical lower surface 110 of the frictional engagement member 106. The intermediate locking member 102 has an interior cylindrical surface 103 that is adapted to be in close engagement with the outer surface 108. In one form the frictional engagement member 106 rotates with respect to the lower portion 100 and is adapted to be biasedly repositioned with respect to the intermediate locking member 102. Of course, other locking mechanisms can be employed; however, the frictional engagement of the partially cylindrical lower surface 110 and the outer surface 108 provides a great deal of flexibility whereby the support handle assembly 40 can be repositioned along the central axis 92 as shown in FIG. 5 by the phantom line indicating the handle 96a. Further, having a cylindrical outer surface 108 of the base region 86, and a substantially corresponding concave partially cylindrical surface 103 and 110 that is perhaps a slightly larger diameter allows for rotation of the support handle assembly 40 about the central axis 92. This is particularly useful in a situation where the user 34 as shown in FIG. 1 desires to pronate or supinate his or her hands 90. Oftentimes, a slight pronation of the hands and forearm regions 90 and 76 from the vertical handle orientation is desirable for a proper ergonomic positioning.

As shown in FIG. 6A, the support handle 96A in one form has a conical or frustoconical forward surface 110A that is adapted to engage the outer surface 108 of the base number 86. In one form, the handle 96A can be of a unitary design which is made of a plastic injected molded piece.

Moving ahead now to FIG. 18, the user 34 has repositioned the pitch adjustment system 36 in a manner so that the pitch angle of the central axis 92 is positioned in a lower orientation in the front region. This orientation of the elbow forearm region 76 of the user 74 allows for a greater amount of force to be applied to the support handle assembly 40. As described above with reference to FIGS. 26 and 27, the orientation of the upper body support assembly 22 can be adjusted by the individual or medical consultant.

There will now be a detailed discussion of the base frame 24 with initial reference back to FIG. 1. As shown in this figure, the base frame 24 comprises a wheel assembly 140 and a frame 142. The frame 142 has a longitudinally forward region 144 and a longitudinally rearward region 146. A longitudinally medial region 143 is positioned in between the regions 142 and 144. Located in the longitudinally rearward portion 146 are first and second base posts 148 and 150 (see FIG. 3). FIG. 3 further shows the base frame 24 having a first lateral region 152 and a second lateral region 154. Located in the longitudinal medial region 143 is a laterally extending support member 160. The laterally extending support member 160 has a longitudinally rear-

ward surface **162** and is connected at a first connection point **164** to the first lateral region and further connected to the connection point **166** at the second lateral region **154**. As shown in FIG. **12**, the laterally extending member **160** is adapted to be reorientated in a manner such that the connection points **164** and **166** are positioned closer to one another. In one form, the laterally extending member **160** comprises first and second intermediate linkages **170** and **172** as well as central linkage **174** that is pivotally connected thereto.

The frame **142** comprises a first lateral frame member **176** and a second lateral frame member **178**. In one form, the first and second lateral frame members **176** and **178** are comprised of a tubular-like member made of aluminum having a sufficient structural moment of inertia to withstand loads and moments exerted thereon. The first and second lateral frame members **176** and **178** have a longitudinal forward region that is attached to a forward frame member **180** that is located in the longitudinally forward region **144**. As shown in FIG. **12**, the longitudinally forward portions of the first and second lateral frame members **176** and **178** are both or either one pivotally attached to the forward frame member **180**. In one form, the second lateral frame member **178** is fixedly attached to the forward frame member **180** and the first lateral frame member **176** is pivotally attached to the forward frame member **180** whereby the base frame **24** has a first position that is an operational position which is indicated by the dashed line **176'** in FIG. **12**. The base frame **24** further has a closed position or storage position indicated by the dark line for the first lateral frame member **176**. When the base frame is in the stored position as shown in FIG. **12** (as well as the mobile support system **20** when the first and second support members **21** and **25** are attached thereto in a manner as shown in FIGS. **28** and **29**), it is particularly conducive to be stored in a more confined space such as the back seat of a vehicle or in the trunk of a car. Further, to reduce the net volume of the device and to make it less cumbersome, the first and second support members **21** and **25** that are best shown in FIGS. **28** and **29** can be removed from the base posts **148** and **150** of the base frame **24**.

Of course a variety of laterally extending support members **160** as shown in FIGS. **3** and **12** can be employed with various linkage type assemblies. The linkage assembly as shown in this figure is conducive to allow for flexibility in the collapsing of the first and second lateral frame members **176** and **178**. It should further be noted that the various members comprising the laterally extending support member **160** are constructed in one form of C-channel-like members comprising the linkages **170**, **172** and **174** to maximize the structural movement of inertia of this member to minimize the rotational torques placed on the base frame **24** in operation. For example, to reduce the amount of torque about a longitudinally extending center axis of the base frame **24**, having C-channel members for the linkages **170**, **172** and **174** are particularly conducive for strengthening and adding rigidity to such a movement applied thereon. As shown in FIG. **11**, the depth of the linkages **170**, **172**, and **174** are approximately twice that of the first and second lateral frame members **176** and **178** in one form. Further, it should be noted that the lower portion of the center linkage **174** has laterally extending wing portions **175** that are adapted to engage the lower surface of linkages **170** and **172** whereby this positive engagement increases the rigidity of the linkage **160**.

There will now be a discussion of the adjustment system of the upper body support assembly **22** with respect to the base frame **24** and with initial reference to FIGS. **7-10**. As

shown in these figures, the locking mechanism **143** in general is adapted to adjustably and fixedly position the extendable post **42** with respect to the base post **148**. FIG. **7** shows a locking mechanism **180**. In general, the locking mechanism **180** comprises a sleeve insert **182** and a circumferential restrictor **184**. As shown in FIG. **8**, the sleeve insert **182** has an outer surface **184** that is adapted to engage the inner surface **186** of the base post **148**. The sleeve insert **182** further comprises a slotted region **188** adapted to allow circumferential restriction of the sleeve insert **182** so the net circumference decreases of the inner conical surface **190**. The inner conical surface **190** is adapted to frictionally engage the outer conical surface **192** of the extendable post **42** as shown in FIG. **7**. In one form, the circumferential restrictor **184** is a common latch assembly having a latch **194** as shown in FIGS. **9** and **10**. This quick release latch assembly that is well-known in the industry is particularly conducive for rapidly adjusting the circumferential restriction to frictionally engage the base post **148** to the extendable post **42**. However, in one form the extendable post **142** is comprised of vertically spaced gnarled regions **196** that are spaced at vertical increments indicated at **198** in FIG. **9**. In general, the vertically spaced gnarled regions **196** allow for a rough region where the inner surface **190** of the sleeve insert **182** can get a better frictional engagement thereof. Further, having the gnarled regions spaced at intervals indicated at **198** is conducive for ensuring that the first and second extendable posts **42** (where the second extendable post is not shown but adapted to engage the base post **150** shown in FIG. **3**) can be more easily adjusted to the same height, whereby the number of gnarled regions that are visible to the individual assist in ensuring that the first and second upper body supports **27** and **29** are at equal heights with respects to the base frame **24**. Further, a numbering system or other increment type measuring system can be etched into the gnarled region **196** so as to make it possible to quickly identify which gnarled section is in engagement with the locking mechanisms **180**.

There will now be a discussion of the wheel assembly **140** with reference to FIGS. **2, 13-17**, and FIG. **25**. As shown in FIG. **2**, the wheel assembly **140** comprises a longitudinally forward wheel subassembly **200** and a longitudinally rearward wheel subassembly **202**. As shown in FIG. **3**, the longitudinally rearward wheel subassembly **202** comprises a first rearward wheel **204** and a second rearward wheel **206**. The first and second rearward wheels comprise in one form a laterally inward displacing device that is shown in FIGS. **13-17**. For purposes of economy of description, the first laterally inward displacing device **210** will be described in detail with the understanding that the description is relevant to the second laterally displacing device **212** as shown in FIG. **3**.

As shown in FIG. **13**, the first laterally inward displacing device **210** comprises a forward linkage **214** and a rearward linkage **216**. The forward and rearward linkages are pivotally connected to a base region **220** at connection points **222** and **224** respectively. The laterally inward displacing device **210** further comprises a wheel carriage **226** that is pivotally connected to the forward and rearward linkages **214** and **216** at pivot point connections **228** and **230**. In a preferred form the arrangement of the connection points **222**, **224**, **228** and **230** are of a parallelogram nature so the carriage **226** only has translation of movement and little to no rotation about a vertical axis. In other words, the distance between points **222** and **224** is the same as the distance between **228** and **230** as shown in FIG. **13**. Further, the center of rotation of points **222** and **228** are the same distance apart as that of the center

of rotation of points **224** and **230**. Of course in some embodiments it may not be necessary to have translation of movement with the carriage member **226**. However, as described further herein, in one form it is desirable to have the first and second rearward wheels track straight ahead along the path of travel without rotation where the U-shaped casing **232** is rigidly attached to the wheel carriage **226**.

As shown in FIG. **14**, the forward and rearward linkages **214** and **216** extend vertically and taper laterally inwardly from the lower portion to the upper portion. By having linkages that extend vertically, any load that is exerted vertically approximately upon the center of the wheel carriage **226** is more adapted to be handled without a large bending movement acting upon the linkages **214** and **216**.

The first rearward wheel **230** is attached to the U-shaped casing **232** about an axis of rotation **234** as shown in FIG. **16**. The first rearward wheel **230** (which of course is the same as the second rearward wheel not shown) has a ground engagement location **231** at the lower region with respect to the U-shaped member **232** which is defined as the area of contact of the wheel **230** as it rolls along and engages the ground. Of course the forward wheel **233** as shown in FIG. **18** has a ground engagement location **235**. In general, the ground engagement locations of the forward and rearward wheels are such to form a triangular orientation. Where more than one wheel is used in the forward region, it is desirable to have these forward wheels laterally positioned inwardly with respect to the two rearward wheels. In one form, the U-shaped casing **232** is rigidly attached to the wheel carriage **226**. The U-shaped casing and the rearward wheel are adapted to reposition from the position indicated by the dashed line **230'** in FIG. **16** to the solid line **230**, whereby the impact/engagement **240** that is positioned in the more forward region of the laterally inward displacing device **210** and preferably attached to the forward linkage **214** is adapted to engage external objects such as the perimeter frame region of a doorway. Therefore, it can be appreciated that the laterally inward displacing devices **210** that are positioned on both sides of the mobile support system **20** (as shown in FIG. **1**) allow for a wider operating position where the ground engagement locations **231** are positioned laterally wider for additional stability and support, and when approached by a narrow passageway of some sort, the rearward wheels **230** are adapted to position laterally inwardly.

As shown in FIGS. **15** and **17**, the laterally displacing device **210** is shown from a bottom view whereby a biasing member **250** is shown that is connected to the forward and rearward linkages **214** and **216** in a manner so that when the laterally inward displacing devices **210** are orientated in a manner as shown in FIG. **17**, the biasing member **250** is extended and the engagement locations **252** and **254** are separated with respect to the orientation as shown in FIG. **15**. This allows for the laterally inward displacing device **210** to be orientated in a laterally outward position as shown in FIG. **15**, and when an external force biases the forward and rearward linkages **214** and **216** in the laterally inward orientation as shown in FIG. **17**, the biasing member **215** repositions the linkage assembly in a manner as shown in FIG. **15** when the external force is not present.

FIG. **18** shows the forward wheel **233** attached to the U-shaped member **260** which is pivotally attached to the forward post **262**. The forward wheel **233** has a forward ground engagement point that is positioned laterally inwardly with respect to the first and second longitudinally rearward ground engaging points **231**.

Now referring ahead to FIG. **25**, there is shown another variation of the mobile support system **20** whereby the first rearward wheel **204'** is of a sportier design whereby the rearward wheel **231'** has a diameter **270** that is larger and more adapted for an unpredictable ground environment such as trail running or the like. The diameter **270** can be between 8 inches and 20 inches in the broader scope and a diameter of approximately 14 inches is of a desirable size to overcome many types of obstacles. The variation as shown in FIG. **25** is in general a sportier model and in one form the rearward wheel **231** (of course there are first and second rearward wheels, but only the first rearward wheel on the first lateral side is shown in this figure) is directly attached to the base frame **24**. A quick release system **272** which is similar to the locking mechanism **180** as shown in FIGS. **9** and **10** can be employed where the first rearward wheel **204** (which of course is similar to the second rearward wheel not shown in this figure) is directly attached to the base frame **24**. The forward wheel **233'** has a similar locking system **274** that is attached to the front fork **276**. The front fork and locking system **274** are similar to others in the industry in such that it is advantageous to remove the forward wheel **233'** to store the mobile support system in a confined area such as the trunk of a car or to reduce the net volume for purposes of shipping or otherwise transporting the mobile support system.

Now referring to FIGS. **19-24**, there are shown various modifications and additions to the mobile support system **20** to suit particular needs of the individual **34**. FIG. **19** shows the individual **34** where the right leg **300** is supported on a limb support **302**. In one form, the support pad **302** is fixedly attached to the base post **148**. The limb support **302** can be attached to the base post **148** by any variety of foreseeable connecting mechanisms; further, the limb support **302** can be an aftermarket type purchase that is retrofitted to a mobile support system **20** on an as-needed basis depending upon the needs of the individual **34**.

FIGS. **20-21** show another modification whereby a seat attachment **320** is provided. The seat attachment **320** has a lower surface that is adapted to rest upon the laterally extending support member **100**. The laterally extending support member **100** can be provided with an engagement type slot whereby an extension of the seat attachment **320** is adapted to engage such a slot. Further, the seat attachment **320** can be repositioned vertically so the laterally extending support member **100** can be reconfigured into the stored/closed position as shown in FIG. **12**. In one form, the seat attachment **320** can be pivotally attached at location **322** and adapted to be vertically displaced and rotated therefrom. In other words, as the seat attachment **320** is positioned vertically with respect to the base frame **24**, the seat attachment **320** rotates about the vertical axis of connection point **322** to be substantially aligned in the longitudinal direction for storage purposes. It should be further noted that as shown in FIG. **20**, the elbow support region **38** is well-suited to rest the forearms **76** of the individual **34**. Of course the upper body support assembly **22** can be adjusted in a manner as described above whereby the heights of the elbow pad **70** are adjusted so as to provide a proper ergonomic position for the individual **34**.

As shown in FIGS. **22-24**, a basket area **334** is provided. As shown in FIG. **23**, the basket area **334** has first and second lateral regions **336** and **338**. The first and second lateral regions **336** and **338** are attached to support rods **340** and **342** that have forward and rearward ends that are attached to the base frame **24**. In one form, the central region **344** is made from a mesh-like material that is lightweight

11

and adapted to have particulate matter such as sand and dirt pass therethrough. The basket area 334 is well-suited to hold particular items of interest to the individual using the mobile support system. Such items that can be contained therein are oxygen if this is a necessary component for the individual, or other items of convenience such as bags, towels, food and drink, a purse, etc. FIG. 24 indicates that the central region 344 can rest substantially below the first and second lateral frame members 176 and 178. The basket can further be provided with first and second lateral side walls 350 and 352 to define a central chamber region 354 adapted to hold items of interest therein.

As shown in FIG. 30, there is another embodiment where a brake system 420 is employed. The brake system has first and second clamping members 422 and 424. The brake system can be a common type of breaking apparatus that is well-known in the art. An extension from the cable can disconnect whereby the frictional engagement members 426 and 428 separate rearwardly greater than the lateral width of the front tire 430 whereby the front clamping mechanism 432 can allow the front tire to be disengaged from the fork assembly. The breaking system 420 is in operational engagement with the control line 340.

As shown in FIG. 31, the line 440 is attached to a brake handle system 450 that has a brake lever 452 that is adapted to pivot about the pivot pin 454 and exercise some mechanical leverage to extend an internal cable within the control line 440 to operate the brake system 420 is shown in FIG. 30. In one form, the control line can be discreetly placed within the base member 460. The upper body support system 462 in one form can be a rigid embodiment whereby the handle 464 and elbow support 466 are at a fixed position and are not adjustable.

Therefore, it can be appreciated that the above noted modifications can be used individually or in combination for a variety of arrangements to suit the needs of the individual 34.

I claim:

1. A mobile support system having a longitudinal and lateral axis adapted to support an individual having a leg and right elbows and left and right hands, the mobile support system comprising:

- a) a base frame comprising a first lateral frame member and a second lateral frame member, the first and second lateral frame members forming a central unobstructed region adapted to provide free motion of the leg of the individual,
- b) a wheel assembly attached to the base frame and comprising a longitudinally rearward wheel subassembly and a longitudinally forward wheel subassembly, where the longitudinally rearward wheel subassembly comprises first and second longitudinally rearward wheels each having ground engagement locations, the longitudinally forward wheel subassembly having a ground engagement location that is positioned laterally between the ground engagement locations of first and second longitudinally rearward wheels, the longitudinally rearward wheel assembly is comprised of a laterally inward displacing device that is adapted to reposition the first and second longitudinally rearward wheels laterally inwardly when biased by an external force and the laterally inward displacing device of the longitudinally rearward wheel assembly is comprised of a four bar linkage assembly having a forward linkage and a rearward linkage that are both pivotally attached to the base frame and first and second wheel carriages of the first and second longitudinally rearward wheels,

12

such that when the wheel carriage is repositioned laterally, the first and second wheel axes of rotation remain substantially aligned in the lateral direction,

- c) an upper body support assembly attached to the base frame, the upper body support assembly comprising:
  - an elbow support region comprising first and second elbow supports adapted to support the left and right elbows of the individual,
  - a support handle assembly comprising first and second support handles adapted to be grasped by left and right hands,
- d) whereas the body weight of the individual is adapted to be partially supported by the upper body support assembly whereby a portion of the weight is distributed to the elbow support region and a portion of the weight is distributed to the support handle assembly.

2. The mobile support system as recited in claim 1 where the first and second support handles are engaged to the base region by an intermediate locking member, whereby the support handle has a lower region that is threadedly engaged to an open recess of the intermediate locking member's lowermost region of the support handle and engages the outer surface of the base region to fixedly and temporarily position the support handle assembly to the base region.

3. The mobile support system as recited in claim 2 whereby the base region is cylindrical and the intermediate locking member has a substantially longitudinally extending cylindrical cavity whereby the intermediate locking member can rotate about the central axis of the base region.

4. The mobile support system as recited in claim 1 whereby the upper body support assembly comprises an extendable post telescopically engaged to a base post of the base frame whereby a locking mechanism is adapted to fix the extendable post with respect to the base post to adjust the height of the upper body support assembly.

5. The mobile support system as recited in claim 1 whereby the upper body support assembly comprises a pitch adjustment system to vary the loads acting thereon between the elbow support region and the support handle assembly.

6. The mobile support system as recited in claim 5 whereby the pitch adjustment system comprises a pivot location and a partially circular slot and an engagement member having a handle region where the engagement member has a first location that is attached to the base frame.

7. The mobile support system as recited in claim 6 where the handle region is adapted to supply a rotational torque and frictionally engage the perimeter region of the partially circular slot.

8. The mobile support system as recited in claim 1 where the mobile support system has a storage orientation where the first lateral frame member is positioned closer in proximity in the lateral direction to the second lateral frame member.

9. The mobile support system as recited in claim 1 where the base frame comprises a laterally extending support member having an upper surface that is adapted to support the individual.

10. The mobile support system as recited in claim 1 where the first and second longitudinally rearward wheels have a diameter that is greater than eight inches.

11. A method of transporting an individual having a bodyweight and center of gravity, a leg and right elbows and left and right hands, the method comprising:

- a) retrieving a mobile support system having a longitudinal and lateral axis adapted to support an individual, the mobile support system comprising a base frame comprising a first lateral frame member and a second

13

lateral frame member, the first and second lateral frame members forming a central unobstructed region adapted to provide free motion of the legs of the individual, a wheel assembly attached to the base frame and comprising a longitudinally rearward wheel sub-assembly and a longitudinal forward wheel subassembly, where the longitudinally rearward wheel subassembly comprises first and second longitudinally rearward wheels each having ground engagement locations, the longitudinally forward wheel subassembly having a ground engagement location that is positioned laterally between the ground engagement locations of first and second longitudinally rearward wheels; the longitudinally rearward wheel assembly being comprised of a laterally inward displacing device that is adapted to reposition the first and second longitudinally rearward wheels laterally inwardly when biased by an external force and the laterally inward displacing device of the longitudinally rearward wheel assembly is comprised of a four bar linkage assembly having a forward linkage and a rearward linkage that are both pivotally attached to the base frame and first and second wheel carriages of the first and second longitudinally rearward wheels, such that when the wheel carriage is repositioned laterally, the first and second wheel axes of rotation remain substantially aligned in the lateral direction; an upper body support assembly attached to the base frame, the upper body support assembly having an elbow support region comprising first and second elbow supports adapted to support the left and right elbows of the individual and a support handle assembly comprising first and second support handles adapted to be grasped by left and right hands,

b) positioning the body weight of the individual in a manner to be partially supported by the upper body support assembly whereby a portion of the weight is distributed to the elbow support region and a portion of the weight is distributed to the support handle assembly to distribute a portion of the individual's body weight thereon.

12. The method as recited in claim 11 whereby the upper body support assembly is extended by an extendable post telescopically engaged to a base post of the base frame whereby a locking mechanism is adapted to fix the extendable post with respect to the base post to adjust the height of the upper body support assembly.

13. The method as recited in claim 11 whereby the upper body support assembly comprises a pitch adjustment system to vary the loads acting thereon between the elbow support region and the support handle assembly.

14. The method as recited in claim 11 where the mobile support system is positioned in a storage orientation following a the transporting of the individual where the first lateral frame member is positioned closer in proximity in the lateral direction to the second lateral frame member and the total lateral width of the mobile support system is reduced and placed in a vehicle for transporting.

15. A mobile support system having a longitudinal and lateral axis adapted to support an individual having a leg and right elbows and left and right hands, the mobile support system comprising:

14

- a) a base frame comprising a first lateral frame member and a second lateral frame member, the first and second lateral frame members forming a central unobstructed region adapted to provide free motion of the leg of the individual,
  - b) a wheel assembly attached to the base frame and comprising a longitudinally rearward wheel subassembly and a longitudinal forward wheel subassembly, where the longitudinally rearward wheel subassembly comprises first and second longitudinally rearward wheels each having ground engagement locations, the longitudinally forward wheel subassembly having a ground engagement location that is positioned forwardly and laterally between the ground engagement locations of first and second longitudinally rearward wheels, the longitudinally rearward wheel assembly being comprised of a laterally inward displacing device that is adapted to reposition the first and second longitudinally rearward wheels laterally inwardly and is comprised of a four bar linkage assembly having a forward linkage and a rearward linkage that are both pivotally attached to the base frame and first and second wheel carriages of the first and second longitudinally rearward wheels, such that when the wheel carriage is repositioned laterally, the first and second wheel axes of rotation remain substantially aligned in the lateral direction,
  - c) an upper body support assembly attached to the base frame, the upper body support assembly comprising:
    - an elbow support region comprising first and second elbow supports adapted to support the left and right elbows of the individual, a support handle assembly comprising first and second support handles adapted to be grasped by left and right hands,
  - d) whereas the body weight of the individual is adapted to be partially supported by the upper body support assembly whereby a portion of the weight is distributed to the elbow support region and a portion of the weight is distributed to the support handle assembly and the mobile support system has a storage orientation where the first lateral frame member is positioned closer in proximity in the lateral direction to the second lateral frame member.
16. The mobile support system as recited in claim 15 whereby the upper body support assembly comprises a pitch adjustment system to vary the loads acting thereon between the elbow support region and the support handle assembly and the pitch adjustment system comprises a pivot location and a partially an engagement member having a handle region where the engagement member has a first location that is attached to the base frame and where the handle region is adapted to supply a rotational torque and frictionally engage the perimeter region of the engagement member.

\* \* \* \* \*