



US007238126B1

(12) **United States Patent**
Wiens et al.

(10) **Patent No.:** **US 7,238,126 B1**
(45) **Date of Patent:** **Jul. 3, 2007**

(54) **GOLF GREEN REPAIR DEVICE METHOD AND APPARATUS**

(75) Inventors: **Terry G. Wiens**, Langley (CA);
Richard D. Edwards, Scottsdale, AZ (US)

(73) Assignee: **Greenfix Golf, Inc.**, Scottsdale, AZ (US)

(*) Notice: Subject to any disclaimer, the term of this patent is extended or adjusted under 35 U.S.C. 154(b) by 72 days.

(21) Appl. No.: **11/101,023**

(22) Filed: **Apr. 6, 2005**

Related U.S. Application Data

(60) Provisional application No. 60/560,324, filed on Apr. 6, 2004.

(51) **Int. Cl.**
A63B 57/00 (2006.01)

(52) **U.S. Cl.** **473/408**

(58) **Field of Classification Search** **473/408,**
473/286; D21/793

See application file for complete search history.

(56) **References Cited**

U.S. PATENT DOCUMENTS

2,857,608 A * 10/1958 Schwartz 473/408
3,185,483 A 5/1965 Klynman
3,456,737 A 7/1969 Rhyme

D239,304 S *	3/1976	Jackson	D21/793
4,007,928 A *	2/1977	Doubt	473/408
4,315,624 A	2/1982	Buckman		
D308,713 S *	6/1990	Sherry	D21/793
4,951,951 A	8/1990	Meyer		
4,984,790 A *	1/1991	Dowdy et al.	473/408
5,121,519 A *	6/1992	Haugom	473/408
5,209,469 A	5/1993	Laskowitz et al.		
6,095,935 A	8/2000	Gooselaw et al.		
D436,152 S	1/2001	Sanford		
6,224,502 B1	5/2001	Warfield		
D452,544 S *	12/2001	Bato	D21/793
6,546,981 B2	4/2003	Cameron		
6,565,458 B1	5/2003	Cameron		
D493,859 S *	8/2004	Lee	D21/793
D502,242 S *	2/2005	Cameron	D21/793
D526,378 S *	8/2006	Blanks	D21/793
2002/0055401 A1	5/2002	Caldwell		

* cited by examiner

Primary Examiner—Steven Wong

(74) *Attorney, Agent, or Firm*—Michael F. Hughes; Hughes Law Firm, PLLC

(57) **ABSTRACT**

A golf green repair tool with a depth limiting feature that has an earth engagement surface that has a forward slant to reposition the raised portion around a crater to the center region of the crater. A prong portion is adapted to be thrust toward the center region of the crater and the repair tool is adapted to do minimal damage to the turf mat and provides a desirable method to repair craters left by impacting golf balls by properly repositioning of the displaced portions.

20 Claims, 10 Drawing Sheets

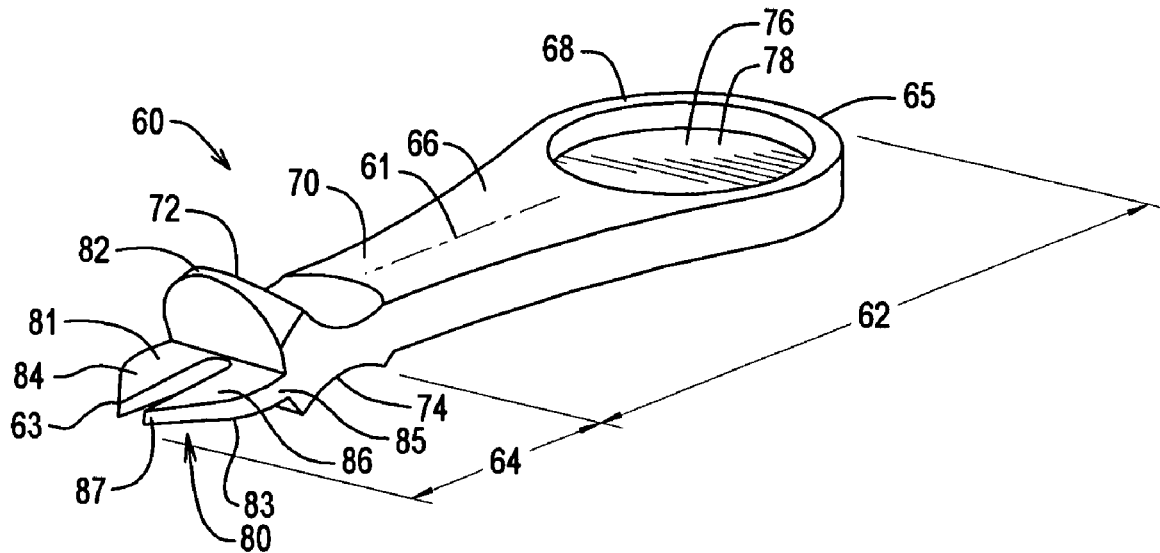

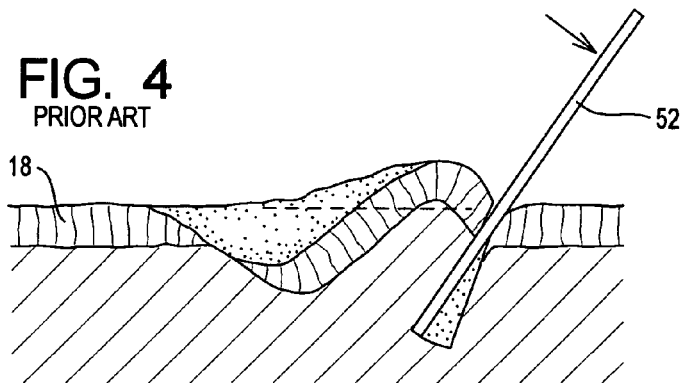
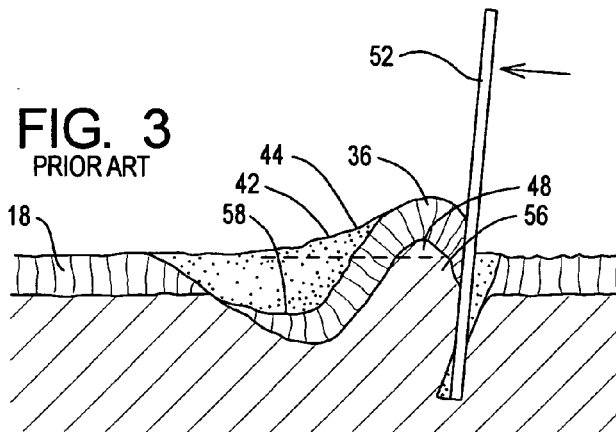
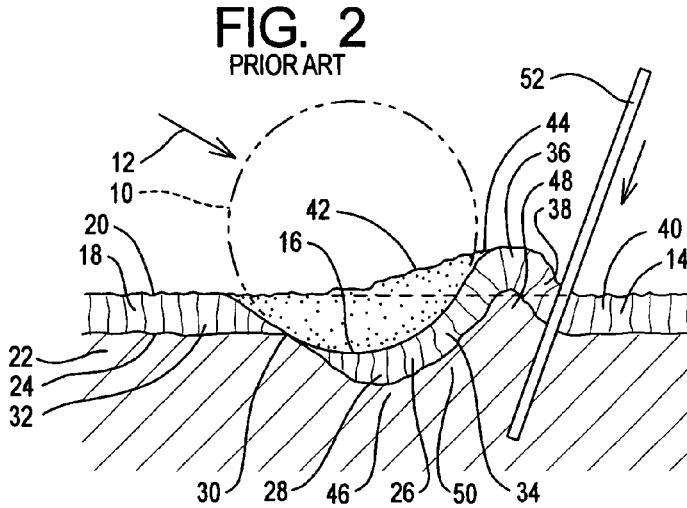
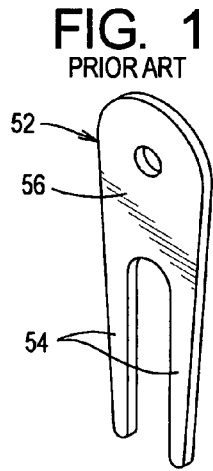

FIG. 5
PRIORART

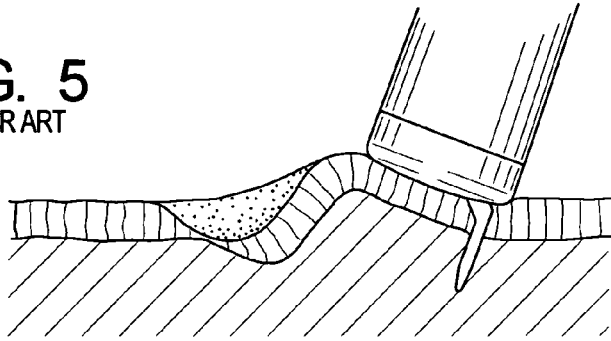

FIG. 6

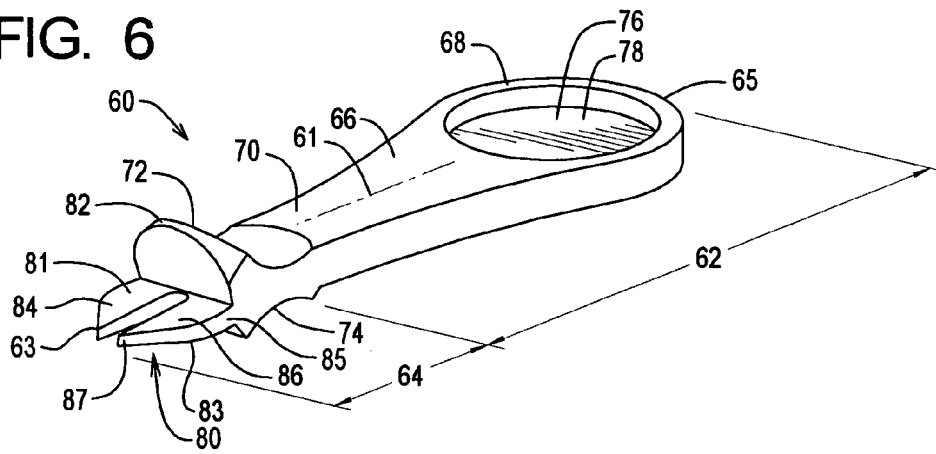

FIG. 7

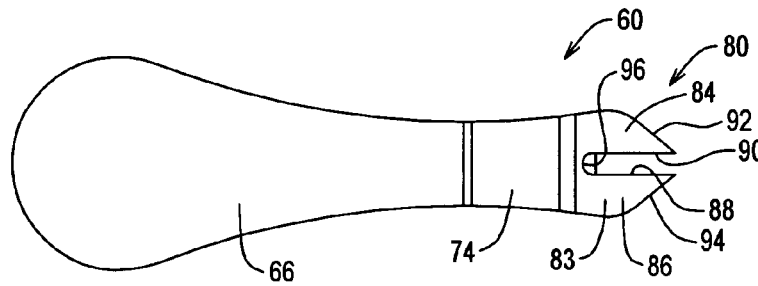

FIG. 8

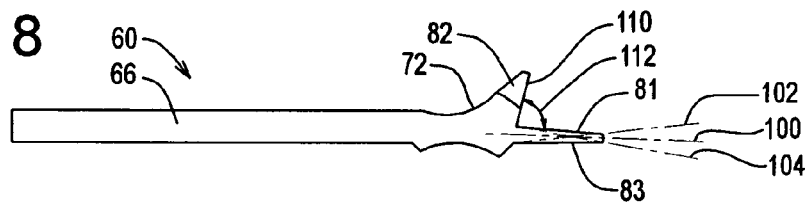

FIG. 8A

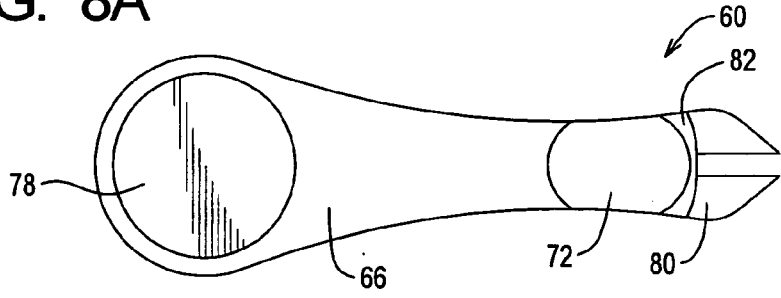

FIG. 8B

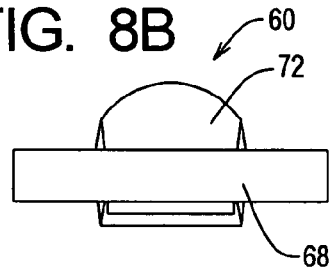

FIG. 8C

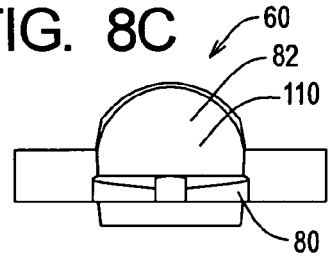
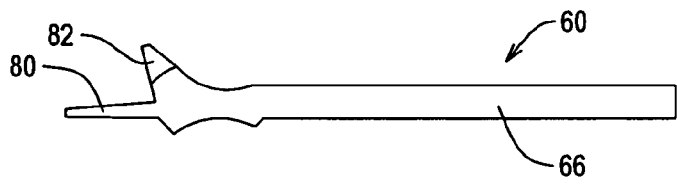

FIG. 8D



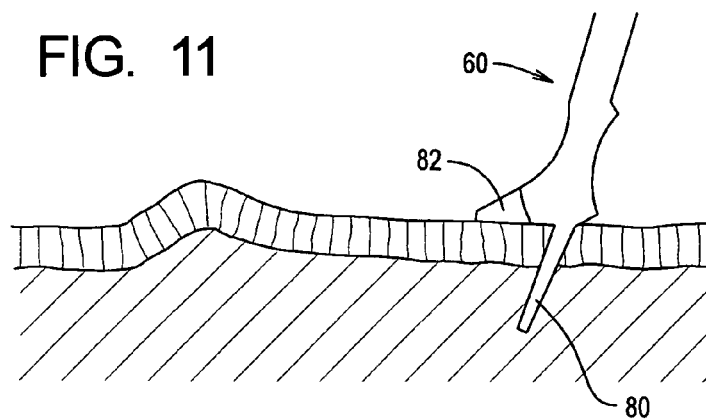
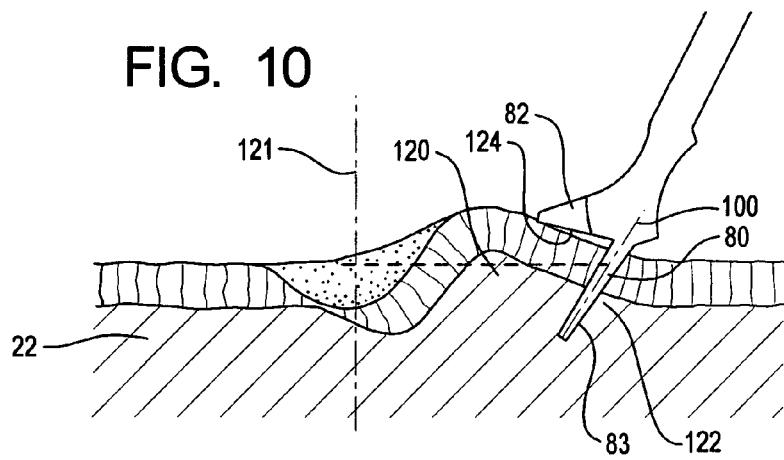
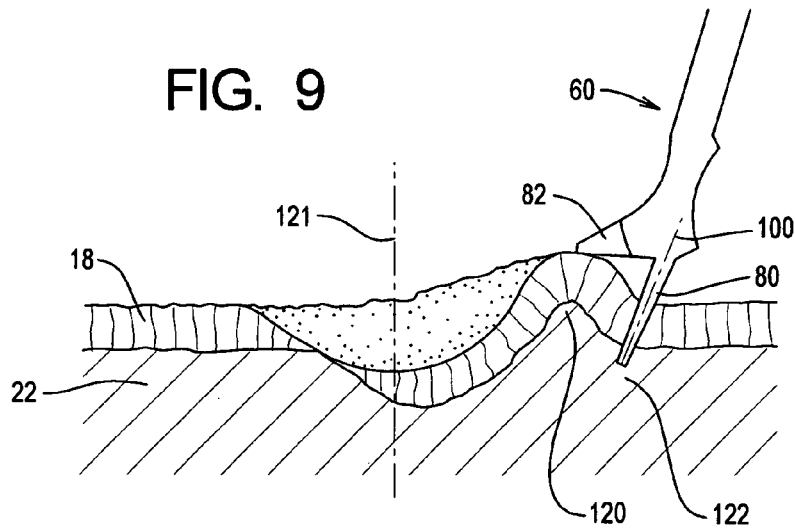

FIG. 12

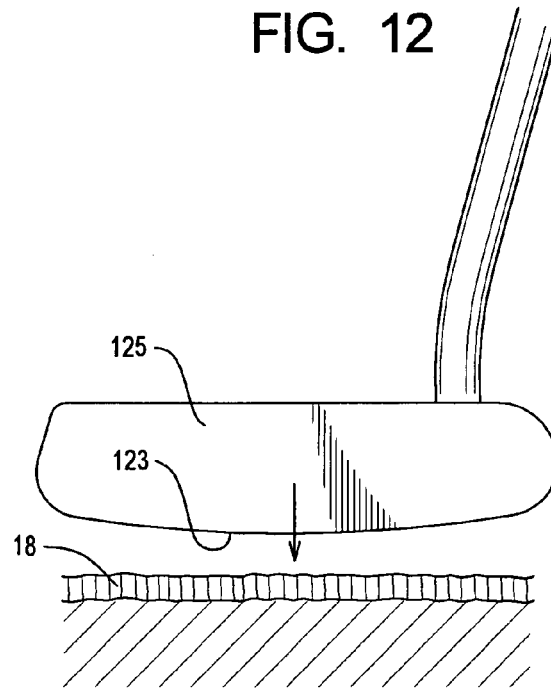

FIG. 13

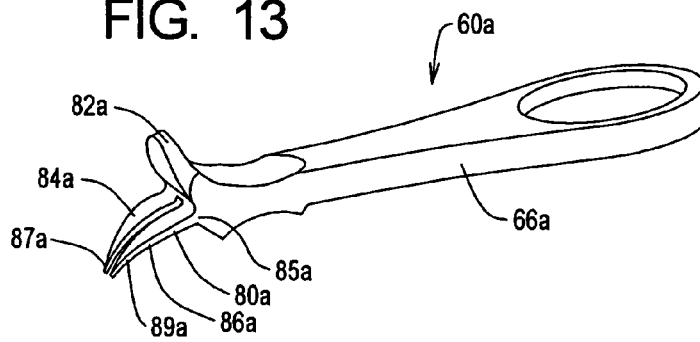
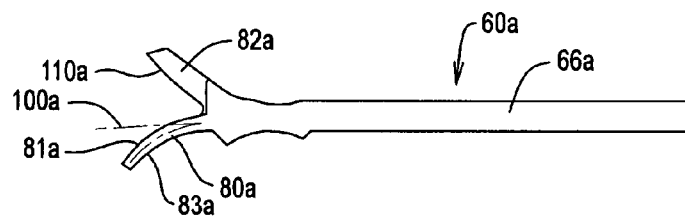

FIG. 13A



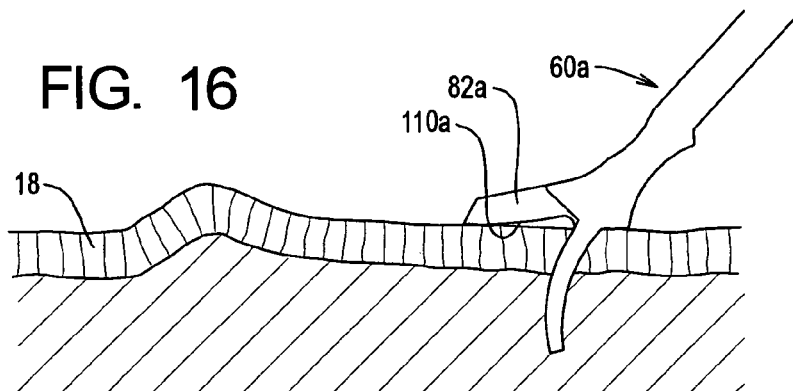
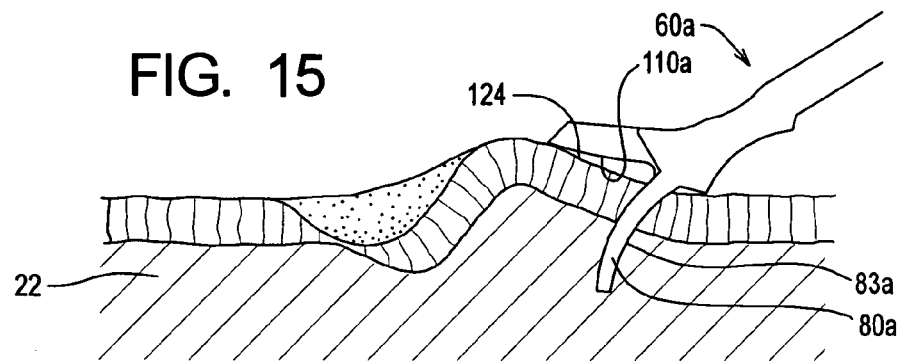
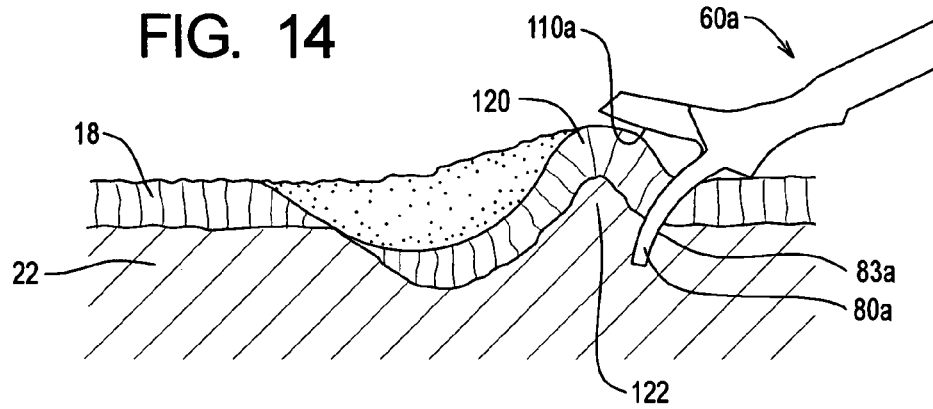

FIG. 17

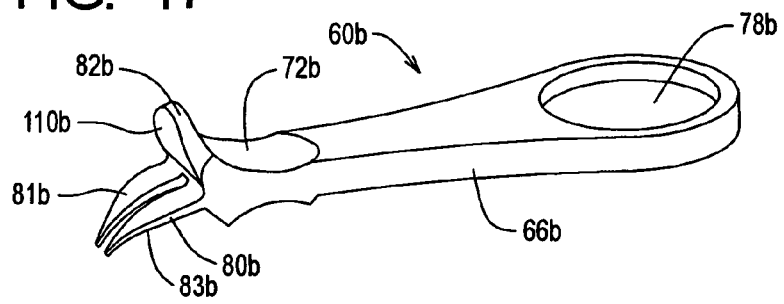

FIG. 18

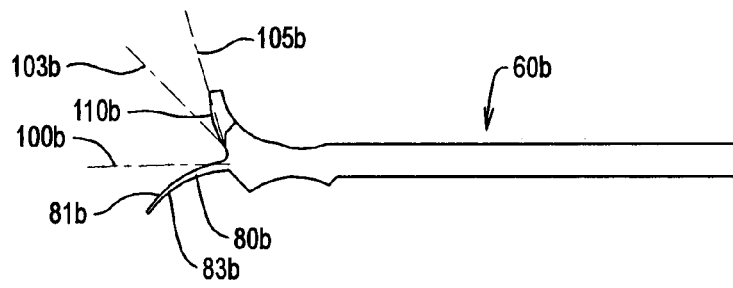

FIG. 19

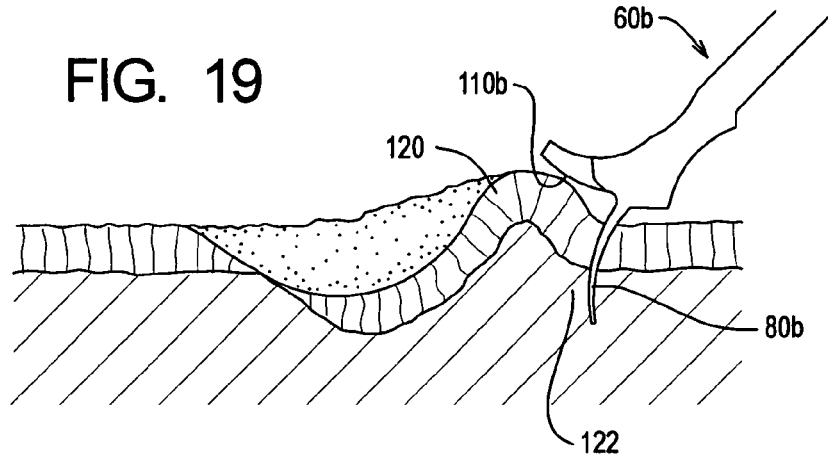

FIG. 20

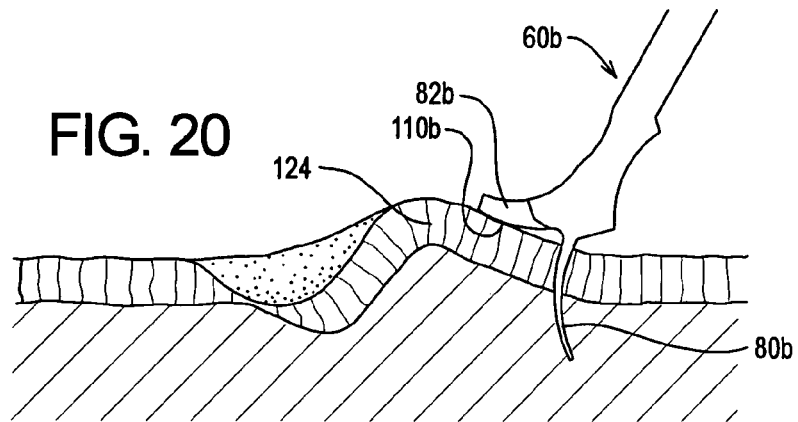

FIG. 21

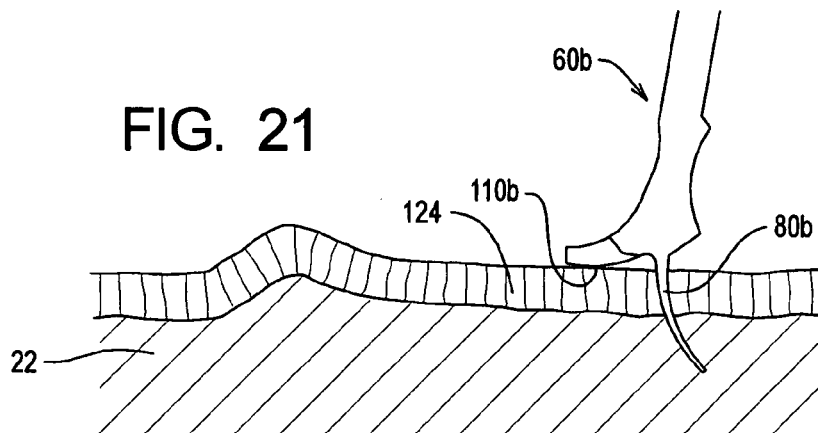

FIG. 22

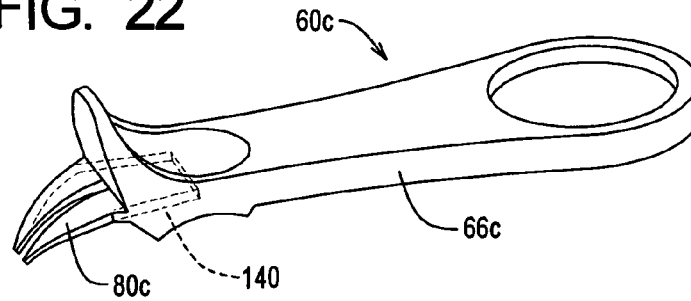

FIG. 23

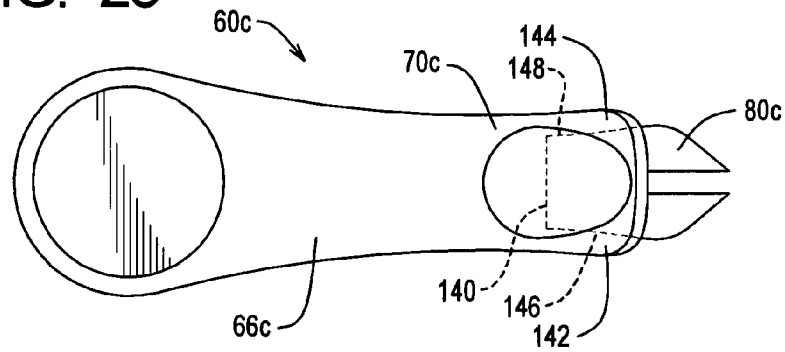

FIG. 24

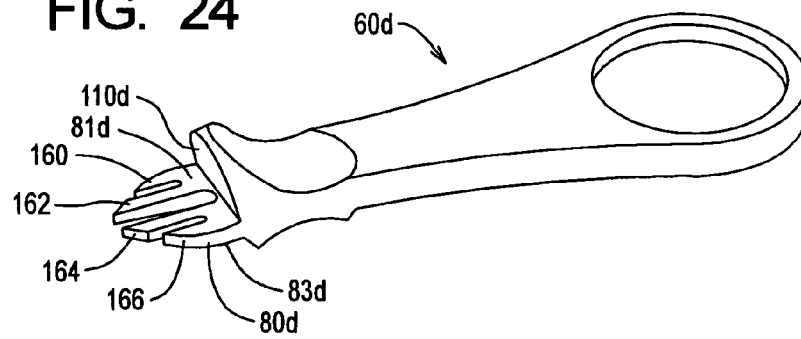

FIG. 25

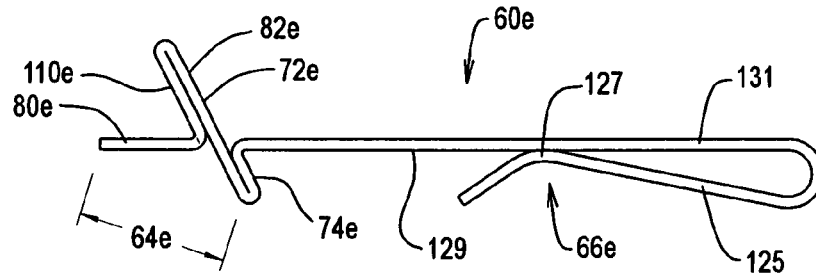

FIG. 26

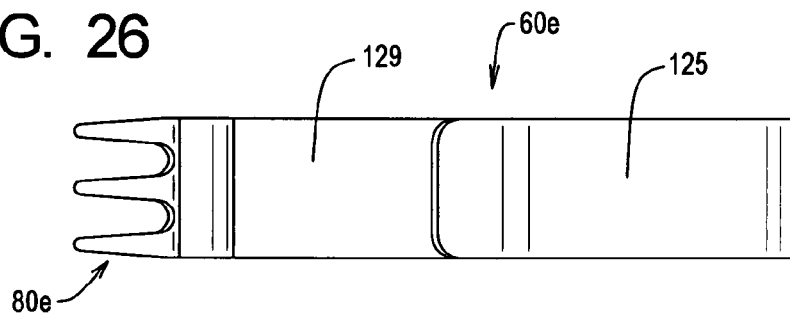
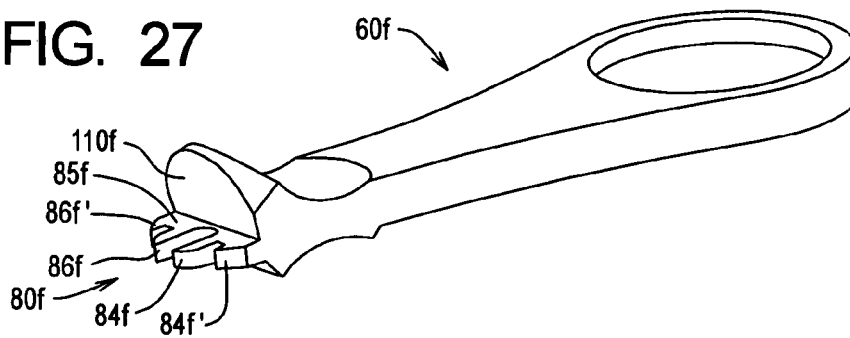

FIG. 27



1

GOLF GREEN REPAIR DEVICE METHOD AND APPARATUS

RELATED APPLICATIONS

This application claims priority benefit of U.S. Ser. No. 60/560,324, filed Apr. 6, 2004.

BACKGROUND OF THE INVENTION

In the sport of golf, greens are generally comprised of a sand and peat moss composition that is well-suited for an upper plane surface comprised of turf plant that is cut to a low height. This upper plane surface provides a relatively low resistance rolling surface for a golf ball and the gradient of the surface is very gradual so there are a minimal number of localized dips and edges that divert a golf ball in its course of travel during a putt. However, on occasion craters or ball marks are created in the green and the most common form of creating a crater is when a golf ball forcefully lands upon a green and causes a ball mark crater thereupon. Often times, a chip shot is taken with a higher numbered iron whereby the ball has a forward and downward arcing trajectory upon impact. Normally, the forward path of the golf ball creates a raised region in the forward direction. It is normal protocol and a courteous procedure to repair the craters and ball marks after they are created.

Prior art methods of repairing the green after a dent is created thereupon comprise two-dimensional tools with extension members adapted to extend into the turf layers and the underlying ground layer immediately therebelow, whereby the prior art lacks a depth limiting feature and a forward surface to manipulate the upper sod layer.

The tool as shown in U.S. Pat. No. 6,223,829 shows a method and apparatus to repair dents in a green formed by golf balls. The apparatus is adapted to be positioned onto the upper handle region of the golf putter or the like. It has been found that having a maneuverable apparatus with a handle region and a rearward surface to aid in the manipulation of the golf green is advantageous for fixing a dent thereon.

Tilting and leveraging of the underground and above ground roots, rhizomes and stolons actually kills the grass, but pushing it forward does not. In essence, the teaching of a retrofit to a putter is to have a flat upper surface such that when your putter is in a stored position in a golf bag, the entire surface is resting on the very bottom portion of the floor of the golf bag.

SUMMARY OF THE DISCLOSURE

A golf green repair tool having a handle region comprising forward and rearward portions about a handle longitudinal axis, with an operating region having forward and rearward regions. In the forward region there is a prong portion having extendable prongs centered substantially about an earth engaging axis. There is further a depth limiting feature having an earth engaging surface that is, for example, less than 80 degrees with respect to the earth engaging axis in one form. Also provided is a thumb engagement region positioned in the rearward region of the prong portion.

BRIEF DESCRIPTION OF THE DRAWINGS

FIGS. 1, 2, 3 and 4 are cross-sectional views taken along a vertical plane parallel to the line of flight of the ball making the dent and extending through the center of the dent in the

2

green, these three views showing in sequence the typical prior art manner of using the "ball mark fixer" in repairing the green;

FIG. 5 shows another prior art device;

FIG. 6 shows an orthogonal view of a tool that is adapted to fix a crater in a green;

FIG. 7 is the bottom view of the tool;

FIG. 8 is a side view of the tool;

FIG. 8a to the top view of the tool;

FIG. 8b is the rearward view of the tool;

FIG. 8c is a front view of the tool;

FIG. 8d is another side view of the tool;

FIGS. 9–12 show progressive views of a method of repairing a crater;

FIG. 13 shows a second embodiment of the tool that is adapted to repair craters;

FIG. 13a is a side view of the second embodiment of the tool;

FIGS. 14–16 are progressive views showing a method of repairing a crater with the tool that is shown in FIG. 13;

FIG. 17 shows a third embodiment of a tool that is adapted to repair craters;

FIG. 18 is a side view of the third embodiment;

FIGS. 19–21 are progressive views of a method of repairing a crater with the embodiment as shown in FIG. 17;

FIG. 22 shows a fourth embodiment of a tool that is adapted to repair craters on a golf green;

FIG. 23 is a top view of the fourth embodiment of the tool;

FIG. 24 is isometric view of a fifth embodiment;

FIG. 25 shows a side view of the sixth embodiment of a greenfix tool;

FIG. 26 shows a top view of the sixth embodiment;

FIG. 27 shows another embodiment where the earth penetrating region has a shorter prong portion.

DETAILED DESCRIPTION OF THE PREFERRED EMBODIMENTS

There will first be a description of how a crater or dent is commonly formed in the golf green by a golf ball with reference to FIGS. 1 through 4. With reference to FIG. 2, there is shown in broken lines a golf ball 10 having descended on a downwardly sloping path (indicated by the arrow 12) to engage the golf green 14 and form the dent or indentation 16. For purposes of description, the golf green 14 can be considered to be made up of two layers. First, there is the upper sod layer 18, which is known as a turf mat, that comprises grass and thatch thereunder which is an interweaving of rhizomes and stolons (horizontal roots) that comprise the green putting surface 20. There is an underlying ground layer 22 immediately therebelow the sod layer 18 which generally comprise roots vertically orientated roots. The interface of the sod layer 18 and the ground layer 22 is indicated at 24.

In the following description, the term "forward" will refer to the direction of the horizontal component of the path of the ball as it impacts the green, and the term "rear" or "rearward" will denote the opposite direction. Further the orthogonal direction of the forward and rearward axes and a vertical axis indicates a lateral axis. Thus, in FIG. 2, the term forward refers to a direction extending toward the right and the lateral axis extends directly out from the figure.

As shown in FIG. 2, when the golf ball 10 strikes the green surface 20 as it travels on its downward and forward path (indicated at 12), the sod layer portion 26 immediately

below and just forward of the impact location of the golf ball is pushed both downwardly and forwardly (to the right as seen in FIG. 2).

More specifically, there is a rear sod portion **28** that has been pushed downwardly and forwardly, as shown in FIG. 2. This figure further shows the sod portion **28** being severed (or at least partially severed) along a separation line **30** from a further rear portion of sod **32** which is just rear of the location where the location of the ball **10** impacts the green surface **20**, and is undisturbed. However, it is to be understood that this pattern of the displacement of the sod layer **18** is not always the same, depending upon the conditions of the green. However, the situation as shown in FIG. 2 is fairly typical. Just forward of the sod portion **28**, there is an upwardly and forwardly sloping sod portion **34** that forms an upwardly and forward sloping part of the dent **16**, and further forward of the portion **34** there is a raised edge portion **36**, which then slopes downwardly and forwardly at **38**, joining a yet further forward portion of the green **40** which remains level and undisturbed.

In addition, the impact of the golf ball **10** also displaces the ground material laterally, as indicated at **42**, so that the raised sod portion **36** and the edge portion **42** create an edge perimeter portion which shall be designated collectively as **44**.

In addition to the sod layer **18** being displaced as described above, the immediate underlying ground layer **22** is also displaced. More specifically, a portion of the ground layer that was immediately below the location where the ball impacts the green is displaced in a manner to create a lower portion **42** just beneath the sod layer portion **28**, a raised edge portion **48** which is just beneath the upper sod edge portion **48**, and an intermediate portion **50**.

Again, it is to be understood that the contours of the dent **16** vary depending upon the path of the ball (whether it is descending in a more vertical slope or more horizontally aligned), the hardness of the underlying ground layer **22**, and resistance of the sod layer **18** to being separated and/or compressed, etc.

In FIG. 1, there is shown the prior art "ball mark fixer" **52**. It can be seen in FIG. 1 that this has a generally U shaped configuration, comprising two generally parallel arms or tines **54** that form the sides of the U, and a base gripping portion **56** that provides opposite gripping surfaces by which the tool **52** can be grasped in a person's fingers and manipulated.

The manner in which this is used is shown in FIG. 2, where it can be seen that the tool **52** is pushed into the ground around the perimeter edge portion **44** of the dent, and as shown in FIGS. 3 and 4, the tool **52** is manipulated by rotating it about a horizontal axis to displace some of the underlying earth **56** toward the center location **58** of the dent **16**. The effect of this is to push the edge portion of the dent forming material, namely the upper edge portion **36** of the sod and the lower portion **48** of the underlying ground layer to the left. After this has been accomplished, the green surface **20** can be flattened to some extent by pressing the head of the club or other surface against the green surface at the location of the dent **16**.

As indicated previously, an alternative method of repairing the green is simply to use a golf tee which is stuck into the green surface a number of times around the perimeter of the dent, again prying the earth and the sod forming the raised edge portion around the dent inwardly toward the center **58**, and then flattening out the green surface.

Overall, the above method is only partially effective. It does cause an overall displacement in the material forming

the sod layer **18** and underlying ground layer **22** toward the dent **16**, but it is rather lacking in restoring the green surface to a condition closer to its original form (i.e. where the sod layer is a uniform layer having a reasonably flat upper green surface **20**). In addition, because of the deep penetration of the tool and the cutting of the roots, rhizomes and stolons, the turf plant affected dies within a few hours, negating any positive impact from the attempt to repair it with the traditional tool and technique.

As shown in FIG. 5 there is an example of a prior art device that is adapted to be mounted to the end portion of a putter. This prior art device allows for a certain amount of repositioning of the edge perimeter portion; however, this device is intended to be employed in a situation where the golfer chooses not to bend over but rather engages in a direct thrusting action along the center axis of the putter shaft to repair a crater.

With the foregoing in mind as background information, there will now be a description of the present invention.

There will now be a discussion of the tool **60** with initial reference to FIG. 6. The tool **60** has a longitudinal axis **61**, a first end **63** and a second end **65**. As shown this figure, the tool comprises a grasping region **62** and an operating region **64**. In general, the grasping region **62** comprises a handle **66** having a rearward portion **68** and a forward portion **70**. Located in the forward portion is a thumb engagement surface **72** and an index finger engaging surface **74** that is positioned substantially opposite to the thumb engagement surface **72**. Located in the rearward portion **68** of the grasping region **62** is a display portion **76** which in one form comprises a recess cavity **78** that is adapted to have an emblem mounted therein. For example, a circular disc like emblem displaying a particular golf club's name and insignia or a golf organization can be mounted therein the recess cavity **78**. The ability to retrofit a disc like or other shaped emblem to a recess region **78** eases manufacture where the tool **60** can be mass-produced by process such as plastic injection molding or the like, and a smaller number of tools to be distributed at a particular club can be retrofitted with the club's emblem.

The thumb engagement surface **72** is in one form the rearward portion of the depth limiting feature **82** describe further herein. In general, the thumb engagement surface **72** provides a surface for the user to thrust a tool **60** along the earth engaging axis **100** described below (see FIG. 8). The index finger engaging surface **74** is adapted to assist grasping the tool **60** and cooperate with the thumb engagement surface **72** so the user can properly handle the tool and thrust it into the turf mat **18** (see FIG. 2). The index finger engaging surface **74** is particularly adapted to provide a normal force to the longitudinal axis **61** of the tool **60** as well as a partial force that is parallel to the earth engaging axis **100** of the tool **60**.

There will now be a discussion of the operating region **64** continuing to reference FIG. 6. The operating region **64** comprises an earth insert (otherwise referred to as an earth penetrating portion) **80**, and a depth limiting feature **82**. In one form, the operating region **64** comprises a first prong and a second prong **84** and **86** respectively, comprising a prong portion. Of course more than two prongs can be employed as shown further herein. As shown in FIG. 7 there is a bottom view of the tool **60** where the first and second prongs have interior edges **88** and **90**. The first and second prongs **84** and **86** further have exterior edges **92** and **94**. It is desirable to have minimal sharp contours on the various interior and exterior surfaces to prevent incising the root structure of the turf mat. In general, the rhizomes and stolons

are laterally extending roots about a horizontal plane. It is desirable to not cut these roots but rather have an earth engaging region **80** adapted to have minimal intrusion but utilize the turf mat **18** to provide a lateral force in the direction of the center of the crater as describe further herein. Therefore, it is preferable to have an angle between the interior and exterior surfaces **88** and **92** as well as **90** and **94** that is approximately less than 45° to prevent the lateral separation of the turf mat's rhizomes and stolons. As described further herein, a plurality of prongs can be employed.

As for the embodiment shown in FIG. 7, the earth engaging region **80** further has a base surface **96** which is generally positioned in close proximity to the depth limiting feature **82**. The base surface **96** as well as the depth limiting feature **82** essentially limit the depth of insertion of the tool **60** when in use.

As further shown in FIG. 6, the earth engaging region **80** further has an upper surface **81** and a lower surface **83**. Of course the upper and lower surfaces **81** and **83** are spread out amongst the various prongs that are employed. In general the upper and lower surfaces **81** and **83** taper slightly from the base region **85** to the tip region **87**.

Now referring to FIG. 8, the tool **60** is shown with an earth engaging axis **100**. In general, the earth engaging axis is an indication of the orientation of the tool when it is a fully inserted position as shown in FIG. 11 and as discussed below. Of course, the earth engaging axis **100** is a general indicator of the position and depending on the profile of the tip regions of the prongs **84** and **86** the axis may shift from a location such as **102** or **104**. As describe further herein the earth engaging region **80** has curved upper and lower surfaces having a different method of defining the earth engaging axis **100**.

As further shown in FIG. 8, the depth limiting feature **82** comprises an earth engaging surface **110** that is adapted to bias the upper sod layer **18** in a manner described below. The angle **112** between the mean sod repositioning surface **110** and the earth engaging axis **100** is less than 90° and a preferred range is between 22° and 80° about a laterally extending axis. A more preferred range for the angle **112** is less than 75° and further is between 30° and 55°. As described in detail with reference to the actual use of the tool in FIGS. 9–11, by having the angle **112** less than 90° and more preferably in the ranges described above, the tool acts as a lateral and downward displacing device in a more effective manner than the prior art tools.

Now referring to FIGS. 9–11, there will be a discussion of the actual use of the tool where as shown in these figures, a crater on a green has occurred and the golfer or golfer's caddy is now attempting to repair the crater. In general, the forward portion of the crater and adjacent lateral portions have the built-up region as described in the beginning of this text. This built-up crater mound region **120** is going to be moved to the center axis of the crater **121**. The most desirable result for this movement is to minimize the disturbance to the root structure. Therefore, it has been found that biasing the mound of the crater in the horizontal plane and downwardly has a minimum impact upon the root structure whereby the ground layer **22** is thrust downwardly and towards the center as well as the sod layer **18**. In essence, the sod layer **18** is repositioned but remains substantially intact whereby the ground layer **22** is shifted back to an approximate original location in the central area of the crater.

As shown in FIG. 9, the earth engaging region **80** has just begun to enter the upper portion of the sod layer **18**. It is

desirable to engage the sod layer **18** at the undisturbed region just outside of the crater mound **120** at an approximate location indicated at **122**. The orientation of the tool **60** should be such that the sod repositioning surface **110** is approximately in the horizontal plane or tilted slightly clockwise as shown in FIG. 9.

Now referring to FIG. 10, the earth engaging region **80** is partially engaged into the upper sod layer **18** and the forward portion of the mound **124** is beginning to be biased rearwardly and downwardly. In general, the lower surface **83** of the earth engaging region **80** is adapted to reposition the depth limiting feature **82** in the rearward direction as the sod repositioning surface **110** moves downwardly. Now referring to FIG. 11, it can be seen how the sod repositioning surface **110** has repositioned the upper sod layer **18** downwardly and rearwardly. Further, the ground layer **22** is repositioned toward the center axis **121** of the crater region. This process can occur around the various forward and lateral regions of the crater to obtain a very desirable putting surface. In general, the center axis of the indentation is an approximate center region perhaps at the lowest point or center impact portion where the ball has struck. In general, the golf green repair tool **60** is adapted to be generally thrust towards this center axis **121** as shown in FIGS. 9 and 10. This directional thrusting is defined broadly and generally indicates a repositioning of the perimeter crater mound region **120** to the central voided region about and around the axis **121**. Further, the definition of thrusting toward the center axis **121** is not limited to an orthogonal movement to the axis, but rather any tangent motion toward the axis which will generally be a direction below the surface **18** and most likely along the earth-engaging axis **100** as shown in FIGS. 9 and 10. As shown in FIG. 12, the bottom portion **123** of the putter can be used as a planing device to substantially flatten out the localized raised portions of the sod **18**.

There will now be a disclosure of various embodiments where similar numerals will be designated with similar components as previous embodiments with an additional alpha numeric character (e.g. 'a', 'b', 'c', etc.) added to the latter portion of the numeric designation.

As shown FIG. 13, the tool **60a** comprises a handle region **66a** and an earth engaging region **80a** as well as a depth limiting feature **82a**. As shown in this Fig., the earth engaging region has a first prong **84a** and a second prong **86a**. The prongs **84a** and **86a** have a general slope about the mean axis extending through the substantial center region **89a** of the prongs downwardly from the base region **85a** to the tip region **87a**. In general, the rounded earth engaging region **80a** can be used for a rolling like effect upon the upper surface of the upper sod layer **18**.

As shown in FIG. 13a, the earth engaging axis **100a** is defined as the base region of the earth engaging region **80a**. Essentially, the earth engaging axis can fluctuate about the lateral axis toward the first transverse direction and the second transverse direction at approximately ten degrees in either direction and at greater degrees in the broader scope. The axis **100a** defines the final orientation of the tool **60a** when it is inserted fully into the green. The earth engaging axis **100a** generally extends through the center region of the earth engaging region **80a**.

Reference is now made to FIGS. 14–16 where the tool **60a** is schematically shown in operation.

In a similar manner as shown in FIGS. 9–11, a crater on a green has occurred and the golfer must repair it. In general, the forward portion of the crater and adjacent lateral portions have the built-up region as described in the beginning of this

text. The tool **60a** is adapted to reposition the sod layer **18** and have it remain substantially intact whereby the ground layer **22** is shifted back to an approximate original location in the central area of the crater.

As shown in FIG. **14**, the earth engaging region **80** has just begun to enter the upper portion of the sod layer **18**. It is desirable to engage the sod layer **18** at the undisturbed region just outside of the crater mound **120** at a location indicated at **122**. The orientation of the tool **60a** should be such that the front portion of the sod repositioning surface **110a** is above in the horizontal plane with respects to the base portion of the surface **110a**.

Now referring to FIG. **15**, the earth engaging region **80a** is partially engaged into the upper sod layer **18** and the forward portion of the mound **124** is beginning to be biased rearwardly and downwardly. In general, the lower surface **83a** of the earth engaging region **80a** is adapted to reposition the depth limiting feature **82a** in the rearward direction as the sod repositioning surface **110a** moves downwardly and has a rolling effect to gradually engage the turf as the tool **60a** rotates in a counterclockwise manner as shown in FIG. **15**. Now referring to FIG. **16**, it can be seen how the earth engaging surface **110a** has repositioned the upper sod layer **18** downwardly and rearwardly. Further, the ground layer **22** is repositioned toward the center of the crater region. This process can occur around the various forward and lateral regions of the crater to obtain a very desirable putting surface.

The FIGS. **17–21** show another embodiment, where as seen in FIGS. **17–18**, the earth engaging region **80b** comprises an upper surface **81b** and a lower surface **83b**. The earth engaging axis **100b** as shown in FIG. **18** is similar to that shown in FIG. **13A**. FIG. **18** further shows the earth engaging surface **110b** that is slightly arced in a longitudinally rearward direction at the tip region. The sod engagement direction changes from an initial direction indicated that **103b** to a final direction indicated at **105b**. As shown in FIG. **19**, the earth engaging region **80b** is inserted to the sod layer **18**. As with the previous examples, in one form it is desirable to engage the sod layer **18** at the undisturbed region just outside of the crater mound **120** at a location indicated at **122**. The orientation of the tool **60b** should be such that the front portion of the earth engaging surface **110b** is above in the horizontal plane with respect to the base portion of the surface **110b**.

FIG. **20** shows the earth engaging region **80b** partially engaged into the upper sod layer **18** and the forward portion of the mound **124** is beginning to be biased rearwardly and downwardly. In general, the lower surface **83b** of the earth engaging region **80b** repositions the depth limiting feature **82b** in the rearward direction as the sod repositioning surface **110b** moves downwardly and has a rolling effect to gradually engage the turf as the tool **60b** rotates in a counterclockwise manner as shown in the Fig. Now referring to FIG. **21**, it can be seen how the sod repositioning surface **110b** has repositioned the upper sod layer **18** downwardly and rearwardly. Further, the ground layer **22** is repositioned toward the center of the crater region. This process can occur around the various forward and lateral regions of the crater to obtain a substantially flat putting surface. It should be noted that in this figure as well as the previous related FIGS. **11** and **16**, the tool can be repositioned at alternative lateral and rearward positions around the crater where these figures can represent the various alternative cross-sectional views to show the progressive flattening of the crater.

FIGS. **22** and **23** show another embodiment of the tool **60c** where the earth engaging region **80c** has an insert region **140** that is adapted to be received in a cavity of the handle region **66c**. This embodiment allows for a metallic type insert that can be stamped out and have an earth engaging region **80c** that is similar to that as shown in FIG. **2** or have the geometry of one of the previous figures whereby the insert region is adapted to rigidly hold the earth engaging region **80c** with respects to the handle region **66c**.

As shown in FIG. **23**, the handle region **66c** has lateral extensions **142** and **144** that adapted to be positioned along the lateral edges **146** and **148** of the insert region **140**. One form of manufacture is to heat the insert region **140** (if it were metallic) and insert this region into the forward portion **70c** of the handle **66c**. In one form a partial cavity can be located in the forward region **70c** whereby the insert region **140** has an interference fit therein.

FIG. **24** shows another embodiment where the tool **60d** has a earth engaging region **80d** that comprises a plurality of prongs **160**, **162**, **164** and **166**. Of course any number of prongs can be employed and additional prongs can aid in the prevention of cutting rhizomes and stolons. The prongs and general comprises an upper surface **81d** and a lower surface **81d**. The lower surface **81d** is adapted to engage the earth and give the biasing force as described above so the sod repositioning surface **110d** can bias the sod in a similar manner as previously described.

Now referring to FIG. **25**, there is shown yet another embodiment whereby operating region **64e** and the handle region/grasping region **66e** are essentially formed from a unitary piece of material, which in one preferred form is bent from a piece of metal to form the various regions and surfaces. The depth limiting feature **82e** is provided with the forward earth engaging surface **110e** that is adapted to engage the various raised perimeter portions of the green in a manner as thoroughly described above. The earth penetrating region **80e** is comprised of one or more prongs that are adapted to engage the upper turf mat of the green with minimal displacement of the root structure. The depth limiting feature **82e** further has a thumb engagement surface **72e** which is adapted to allow the user to provide the downward and horizontal thrusting action towards the center axis (center cavity region) of the ball crater in the green. Further, an index finger engagement surface **74e** can be provided in the lower transverse portion of the tool **60e**.

It should be further noted that in the handle region **62e**, the metal can be bent in a manner to form a hooked portion **125** having a forward portion **127** which is preferably in close engagement to the lower transverse surface **129**. The hooked portion **125** can have a springlike effect with respect to the grasping handle **131** where the forward portion **127** allows a clamping-like action so the green fix repair tool **60e** can be attached to various straps or loops on a golfer's attire or his gear such as his golf bag.

As shown in FIG. **27**, there is another embodiment where the earth penetrating region **80f** has a plurality of prongs **84f** and **86f** as well as the lateral prongs **84f** and **86f**. In general, the length of these prongs from the base region **85f** is much shorter where the primary function of the tool is for repositioning the soil by the earth engaging surface **110f**. The length of the prongs scan be down to $\frac{1}{8}$ of an inch in an extreme form where the primary purpose of the prongs is to maintain the position of the tool **60f** against the perimeter region of the crater.

It can therefore be appreciated that while the present invention is illustrated by the description of several embodiments and while the illustrative embodiments are described

in detail, it is not the intention of the applicants to restrict or in any way limit the scope of the appended claims to such detail. Additional advantages and modifications within the scope of the appended claims will readily appear to those sufficed in the art. The invention in its broader aspects is therefore not limited to the specific details, representative apparatus and methods, and illustrative concepts shown and described. Accordingly, departures may be made from such details without departing from the spirit or scope of applicants' general concept.

We claim:

1. A golf tool having an upper and lower transverse region, the golf tool operatively configured to fix a dent in a green by a golfer with a hand and a thumb, the golf tool comprising:

- a) an operating region having a prong portion extending substantially about a longitudinal axis or toward the lower transverse region of the golf tool,
- b) a depth limiting feature having a substantially continuous earth engagement surface that extends substantially completely across the width of the operating region and that is approximately less than 80° of the longitudinal axis of the golf tool,
- c) a grasping region having a handle portion adapted to be grasped,
- d) a thumb engagement region located in a forward region of the golf tool and adapted to engage the thumb of a golfer.

2. The golf tool as described in claim 1 where the prong portion comprises three or more prongs.

3. The golf tool as described in claim 1 where the prong portion is slanted downwardly in the longitudinal direction.

4. The golf tool as recited in claim 1 where the earth engagement surface is substantially planar.

5. A golf green repair tool configured to fix a crater formed when a golf ball forcefully lands upon a green and causes the crater thereupon, the golf green repair tool comprising:

- a) a handle region comprising forward and rearward portions about a handle longitudinal axis,
- b) an operating region having forward and rearward regions and comprising
 - i) a prong portion having extending prongs centered substantially about an earth engaging axis,
 - ii) a depth limiting feature having a substantially continuous earth engaging surface that extends substantially completely across the width of the operating region and that is equal to or less than 80 degrees with respect to the earth engaging axis,
 - iii) a thumb engagement region positioned in the rearward region of the prong portion.

6. The golf green repair tool as recited in claim 5 whereby the prong portion is comprised of two prongs adapted to penetrate the terrain.

7. The golf green repair tool as recited in claim 5 whereby the prongs curve in the transverse direction from the rearward portion of the operating region to the forward portion of the operating region.

8. The golf green repair tool as recited in claim 5 whereby the angle of the earth engagement surface with respect to the operating axis of the prong portion is less than 50 degrees.

9. The apparatus as recited in claim 5 whereby the handle region further comprises an index finger engaging surface opposing the thumb engagement surface.

10. The golf green repair tool as described in claim 5, where the earth engaging region is adapted to reposition a

perimeter region of a crater on a green toward the center of the crater exerting a horizontal force thereon.

11. A handheld golf green repair tool configured to fix a crater formed by an impact of a golf ball upon a green, the crater having a center region and a perimeter region, the golf green repair tool comprising:

- a) a handle portion comprising forward and rearward regions as well as first and second transverse regions,
- b) a thumb engagement surface positioned in the forward and first transverse regions of the handle portion,
- c) an index finger engaging surface positioned substantially opposed to the thumb engagement surface in the second transverse region,
- d) a substantially continuous earth engaging surface that extends substantially completely across the width of a prong portion and that is slanted in a forward direction operatively configured to engage the perimeter region of the crater and bias the perimeter region to the center region of the crater,
- e) the prong portion having extending prongs extending outwardly from the forward region of the handle, the prong portion operatively configured to pierce the perimeter region of the crater and maintain the position of the golf green repair tool while the earth engaging surface biases the perimeter region to the center portion of the crater region of the crater.

12. The handheld golf green repair tool as recited in claim 11 where the handle portion has a surface defining a cavity adapted to have an emblem mounted therein.

13. The handheld golf green repair tool as recited in claim 11 where the index finger engaging surface is operatively configured to provide a surface where a portion of pressure applied to this surface is directed to the forward region of the handle.

14. The handheld golf green repair tool as recited in claim 11 where the prong portion is comprised of first and second prongs that each comprise a lower surface and exterior edges having minimal sharp contours to prevent incising root structures of the perimeter region of the crater.

15. The handheld golf green repair tool as recited in claim 14 where the first and second prongs taper towards a forward region away from the handle.

16. The handheld golf green repair tool as recited in claim 11 where the prong portion is curved and slants toward the second transverse region.

17. The handheld golf green repair tool as recited in claim 11 where the golf green repair tool can be operated with a single hand by an individual utilizing the tool.

18. The handheld golf green repair tool as recited in claim 11 where the index finger engaging surface has an extension in the second lateral direction operatively configured to engage a forefinger of an individual using the handheld golf green repair tool to aid in applying a force in the forward direction.

19. The golf green repair tool as recited in claim 5 where the golf green repair tool can be operated with a single hand by an individual utilizing the tool.

20. The golf green repair tool as recited in claim 5 where the prong portion is comprised of first and second prongs that each comprise a lower surface and exterior edges having minimal sharp contours to prevent incising root structures of the perimeter region of the crater.