



US00D412190S

United States Patent [19] Graham

[11] **Patent Number: Des. 412,190**
[45] **Date of Patent: ** Jul. 20, 1999**

[54] **STEAM POWERED TOY TUG BOAT**

3,517,455 6/1970 Glass et al. 446/165
3,793,769 2/1974 Tong 446/165
4,846,751 7/1989 Kosoris 446/160

[76] Inventor: **Parker Graham, 2701 Cornwall Ave.,
Bellingham, Wash. 98225**

[**] Term: **14 Years**

Primary Examiner—Raphael Barkai
Attorney, Agent, or Firm—Robert B. Hughes; Hughes &
Schacht, P.S.

[21] Appl. No.: **29/080,330**

[57] **CLAIM**

[22] Filed: **Dec. 4, 1997**

The ornamental design for a steam powered toy tug boat, as shown and described.

[51] **LOC (6) Cl.** **21-01**

[52] **U.S. Cl.** **D21/546**

[58] **Field of Search** D21/542-547;
D12/300, 315, 318; 446/160-165, 88, 87

DESCRIPTION

[56] **References Cited**

FIG. 1 is an isometric view showing the design of the present invention;
FIG. 2 is a side elevational view thereof;
FIG. 3 is a top plan view thereof;
FIG. 4 is a front elevational view thereof;
FIG. 5 is a rear view thereof; and,
FIG. 6 is a bottom view thereof.

U.S. PATENT DOCUMENTS

D. 140,720 4/1945 Ripley D21/542
D. 160,499 10/1950 Hughes D12/315
D. 236,145 7/1975 Tong D21/546
2,388,340 11/1945 Ripley 446/88

1 Claim, 2 Drawing Sheets

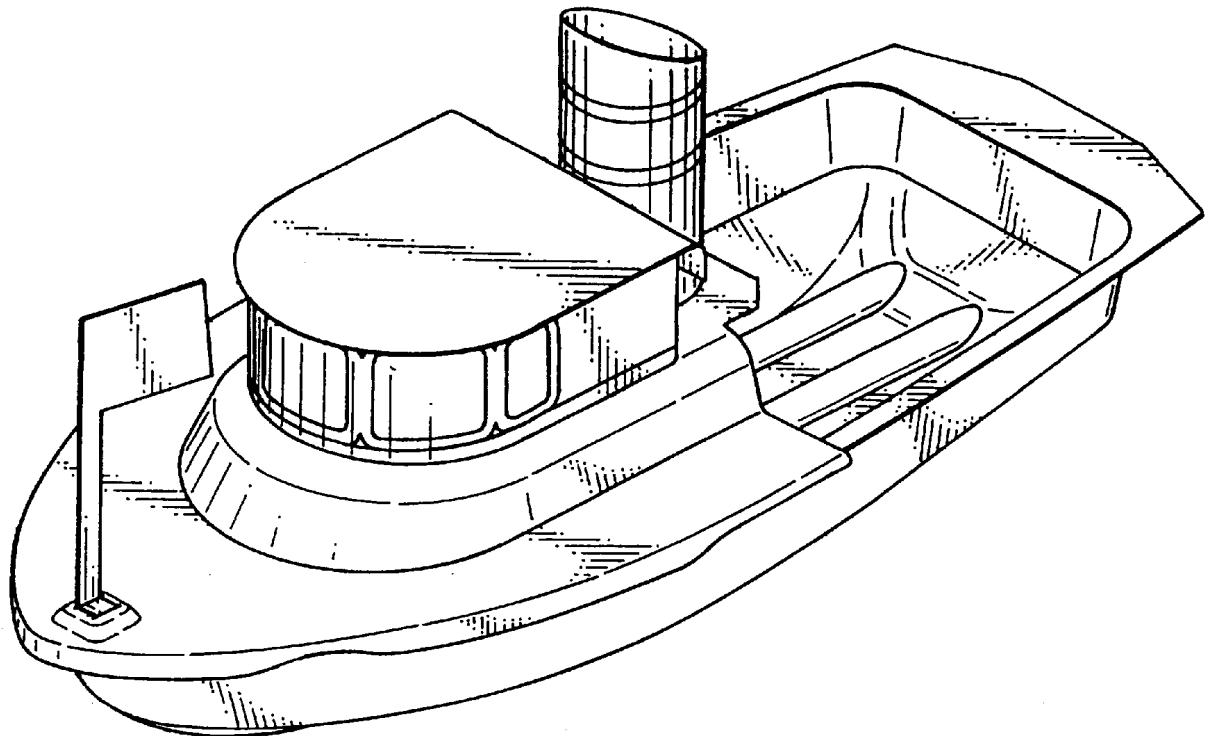

FIG. 1

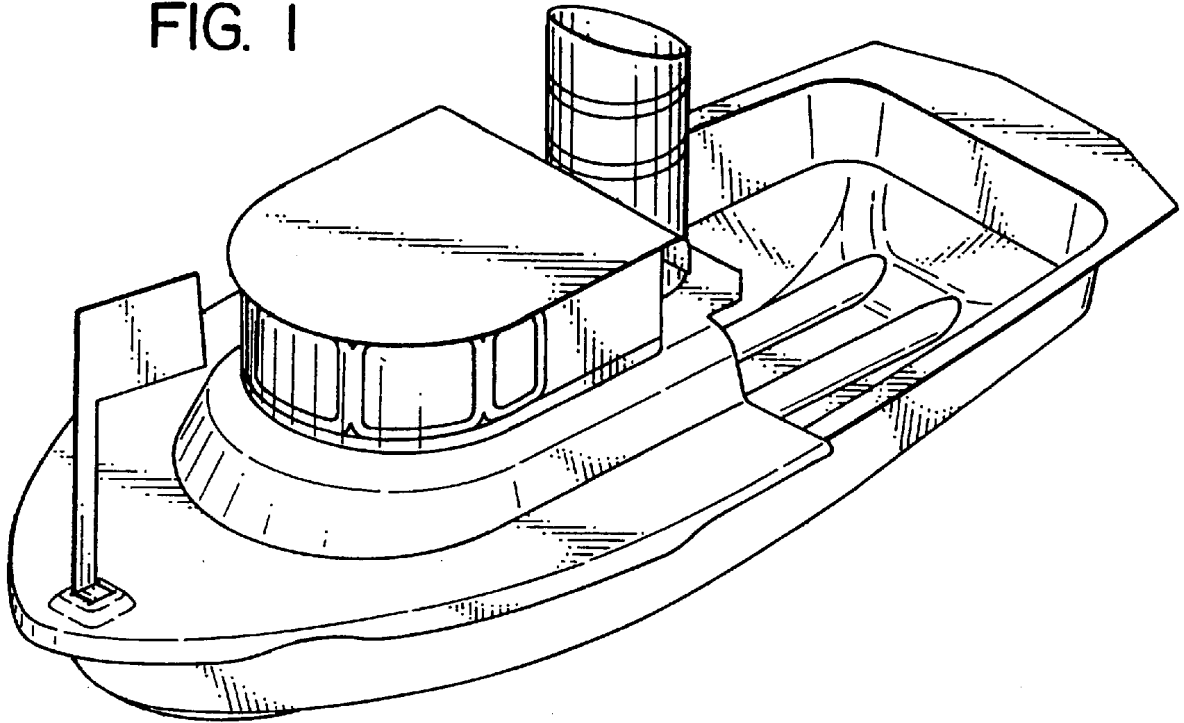

FIG. 2

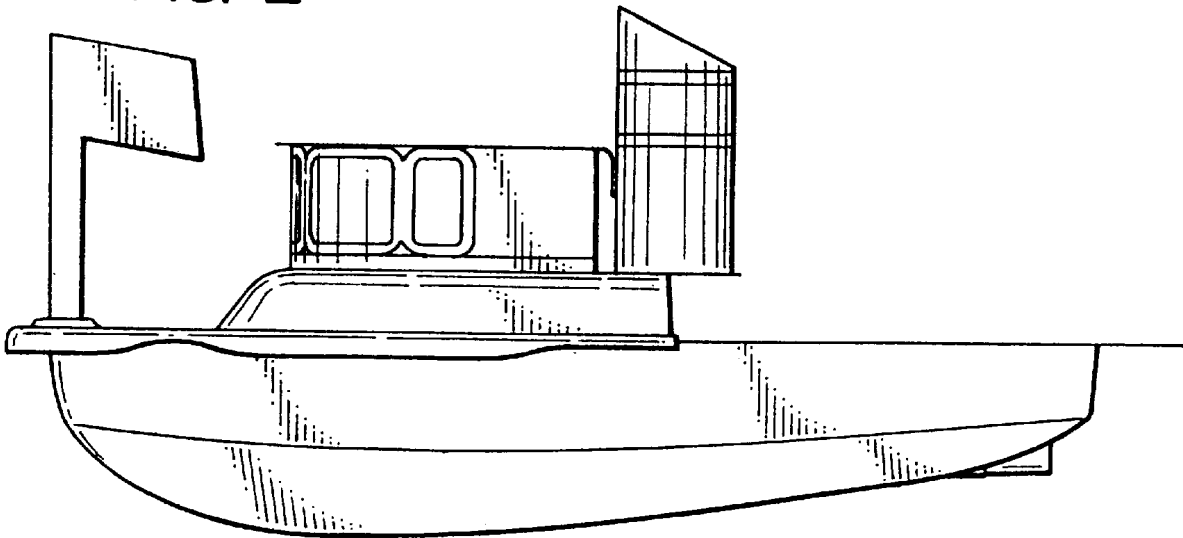

FIG. 3

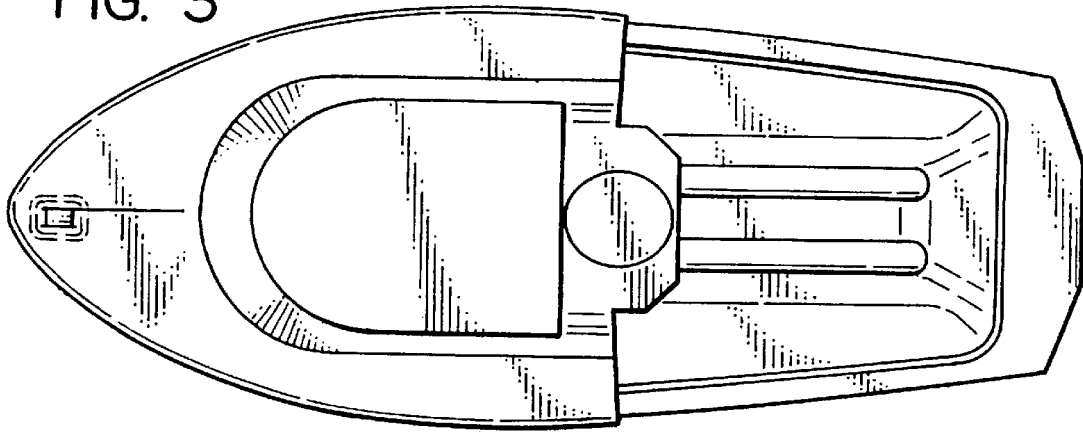

FIG. 4

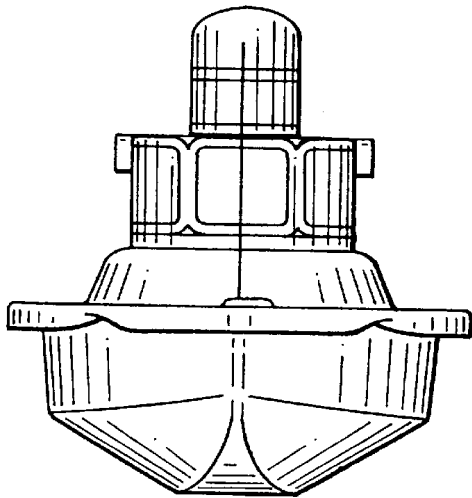

FIG. 5

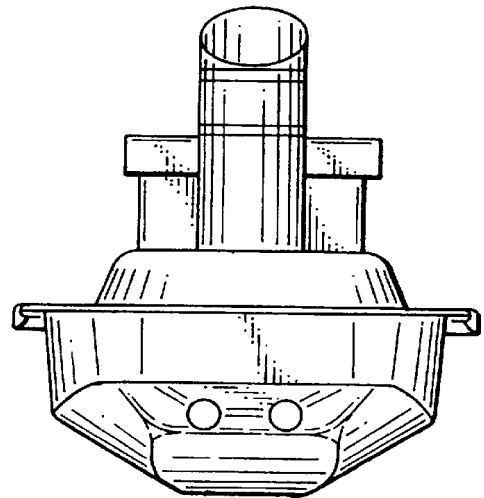

FIG. 6

